

OPTICS

UNIT - I

Interference and interferometers

Interference and Interferometers: Coherence – temporal coherence and spatial coherence – Air wedge – testing the planeness of a surface– Michelson Interferometer – types of fringes – Difference in wavelength of Sodium D1, D2 lines and thickness of a thin transparent plate – Feby-Perot interferometer – formation of fringes. Holography: Holography – recording and reconstruction.

UNIT - II

DIFFRACTION AND OPTICAL INSTRUMENTS

Diffraction : Fresnel's and Fraunhofer diffraction – Fresnel's half period zones – area of the half period zones – zone plate – Comparison of zone plate with convex lens – Fraunhofer diffraction pattern with N slits(diffraction grating) – normal incidence – absent and overlapping spectra of diffraction grating. Optical Instruments: Rayleigh's criterion – Resolving power of a telescope, microscope and grating.

UNIT - III

Polarization:

Polarization – Nicol prism as polarizer and analyzer –Diachronic Polarizer's – Huygens's theory of double refraction in uniaxial crystals – Double image polarizing prisms – Quarter wave plate, Half wave plate –Babine's compensator – Plane, elliptically and circularly polarized light – production and detection – Optical activity, analysis of light by Laurent's half shade polarimeter.

UNIT - IV

Aberrations:

Monochromatic aberrations – spherical aberration –methods of minimizing spherical aberration – Definition of coma, astigmatism and curvature of field, distortion – Method of minimizing spherical aberration – chromatic aberration – Equivalent focal length of two thin lenses – in contact and out of contact method. Eye pieces: Huygens and Ramsden eyepiece –location of

cardinal points. Velocity of light – determination of velocity of light – Kerr cell method

UNIT - V

FibreOptics:

Introduction – fiber optic system – the fiber optic communication compared to metallic cable (electrical) communication– basic principle – total internal reflection – acceptance angle and numerical aperture – types of optical fibers based on material –propagation (transmission) of light through an optical fiber – index profile – fiber configurations – difference between single mode fiber and multimode fiber – difference between step index fiber and graded index fiber – fiber optic communication link.

BOOKS FOR STUDY:

1. N. Subramanian, Brijlal and M.N. Avadhanulu, A text book of Optics, S. Chand & Co, New Delhi, (2012)
2. R. Murugesan and Kiruthiga Sivaprasath, Optics and spectroscopy, S. Chand & Co, New Delhi (2010)
3. P. K. Chakrabarti, Geometrical and Physical Optics, New Central Book Agency (P) Ltd, Kolkata, (2010)
4. Ashok kumar, D.R. Khanna and H.R. Gulati, Fundamentals of optics, S. Chand & Co. Pvt. Ltd (2012)
5. Subir Kumar Sarkar, Optic Fibres and Fibre Optic Communication Systems, S. Chand & Co.,

UNIT-I

INTERFERENCE AND INTERFEROMETERS

Coherence:

- ❖ A wave which appears to be a pure sine wave for an infinitely large period of time or in an infinitely extended space is said to be a perfectly coherent wave. In such a wave there is a definite relationship between the phase of the wave at a given time and at a certain time later, or at a given point and at a certain distance away.
- ❖ Let E represent the electric field associated with the light wave. We assume that

$$E = A \cos (kx - \omega t + \phi)$$

No actual light source, however, emits a perfectly coherent wave.

- ❖ There are two different criteria of coherence: the criteria of time and the criteria of space. This gives rise to temporal coherence and spatial coherence.

Temporal Coherence and Spatial Coherence:

Temporal Coherence:

- ❖ The oscillating electric field E of a perfectly coherent light wave would have a constant amplitude of vibration at an point, while its phase would vary linearly with time.
- ❖ As a function of time, the field would appear as shown in Fig.. It is an ideal sinusoidal function of time.

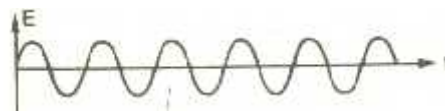

- ❖ However, no light emitted by an actual source produces an ideal sinusoidal field for all values of time.
- ❖ The radiation from an ordinary light source consists of finite size wave trains. Hence the field due to an actual light source will be as shown in Fig..

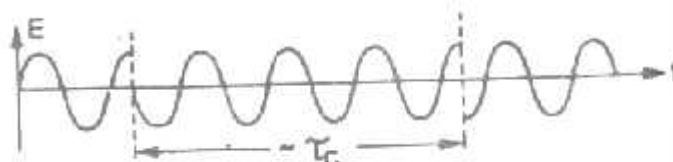

- ❖ Now, in Fig. τ_c represents the average duration of the wave trains, i.e., the electric field remains sinusoidal for time-intervals of the order of τ_c . After this time-interval, the phase changes abruptly.
- ❖ Thus, at a given point, the electric field at times t and $t + \Delta t$ will, in general, have a definite phase relationship if $\Delta t \ll \tau_c$ (almost) never have any phase relationship if $\Delta t \gg \tau_c$. The average time –in-travel for which the field remains sinusoidal (i.e., definite phase relationship exists) is known as “coherence time” of the source and is denoted by τ_c . The distance L for which the field is sinusoidal is given

Spatial Coherence:

- ❖ The spatial coherence is the phase relationship between the radiation fields at different points in space. Two fields at two different points on a wave front of a given electromagnetic wave are said to be space coherence if they preserve a constant phase difference over any time t , i.e., space coherency requires that waves not only are of the same frequency, but that they are in phase in space.
- ❖ Consider young’s double-slit experiment (Fig.). Light emanating from a narrow slit S falls on two slits S_1 and S_2 placed symmetrically with respect to s . Consider a point P on the screen. Let $S_1P = r_1$ and $S_2P = r_2$. The interference pattern observed around the point p at time t is due to the superposition of waves emanating from S_1 and S_2 at times $t - (r_1/c)$ and $t - (r_2/c)$ respectively. If

$$\frac{r_2 - r_1}{c} \ll \tau_c$$

Air wedge – shaped film:

- ❖ Consider a wedge-shaped film of refractive index n enclosed by two plane surfaces OP and PQ inclined at an angle θ . The thickness of the film increases from O to P . When the film is illuminated by a parallel beam of monochromatic light, interference occurs between the rays reflected at the upper and lower surfaces of the film.
- ❖ So equidistant alternate dark and bright fringes are observed. The fringes are parallel to the line of intersection of the two surfaces. The

interfering rays are AB and CD, both originating from the same incident ray SA.

Expression for the fringe width:

❖ The condition for a dark fringe is $2nt \cos r = \lambda$. Here for air $n = 1$. For normal incidence $\cos r = \cos 0 = 1$. Suppose the m th dark fringes is formed where the thickness of the air film is t_m (Fig.2.10). then,

$$2 \times 1 \times t_m \times 1 = m \lambda \text{ or } 2t_m = m \lambda$$

Suppose the $(m+1)$ th dark fringe is formed where the thickness of the air film is t_{m+1} . Then $2t_{m+1} = (m+1) \lambda$

Subtracting (1) from (2), $2(t_{m+1}-t_m) = \lambda$

Let x_{m+1} and x_m be the distances of the $(m+1)$ th and m th dark fringes from O. $d =$ diameter of the wire; $L =$ distance between O and the wire.

Then,

$$\frac{t_{m+1}}{x_{m+1}} = \frac{t_m}{x_m} = \frac{d}{L} = "$$

$$t_{m+1} = \frac{d}{L} x_{m+1}; \quad t_m = \frac{d}{L} x_m$$

Substituting these values in Eq. (3), we get

$$2 \frac{d}{L} (x_{m+1} - x) = \lambda$$

But, $x_{m+1} - x_m = S$ fringe width, or

$$2 \frac{d}{L} S = \lambda$$

$$S = \frac{\lambda L}{2d} = \frac{\lambda}{2\mu}$$

d, λ and L are constants. Therefore, fringe width β is constant. Similarly we consider two consecutive bright fringes; the width λ will be the same.

Experiment to measure the diameter of a thin wire:

- ❖ An air wedge is formed by inserting the wire between two glass plates. Monochromatic light is reflected vertically downwards on to the wedge by the inclined glass plate G (Fig.). A traveling microscope M with its axis vertical is placed above G. The microscope is focused to get clear dark and bright fringes. The fringe width (β) is measured. The length (L) of the wedge also is measured. Knowing λ , the diameter (d) of the wire is calculated using the formula,

$$d = \frac{\beta L}{2s}$$

Testing a surface for planeness:

- ❖ A wedge shaped air film is formed between an optically plane glass plate OP and the surface under test (OQ). The fringes will be straight if the surface under test is perfectly plane. If the surface OQ is not perfectly plane, the fringes will be irregular in shape.
- ❖ In practice, perfectly plane surfaces are produced by polishing the surfaces and testing them from time to time, until the fringes are straight. In testing for planeness, an extended source of light should be used.

Michelson's Interferometer:

Principle:

- ❖ Here, the two interfering beams are formed by division of amplitude. The amplitude of the light beam from an extended source is divided into two parts of equal intensity by partial reflection and refraction.
- ❖ These beams are sent in two perpendicular directions. The two beams are finally brought together after reflection from plane mirrors to produce interference fringes.

Apparatus:

- ❖ M_1 and M_2 are front silvered plane mirrors (Fig. 2.16).

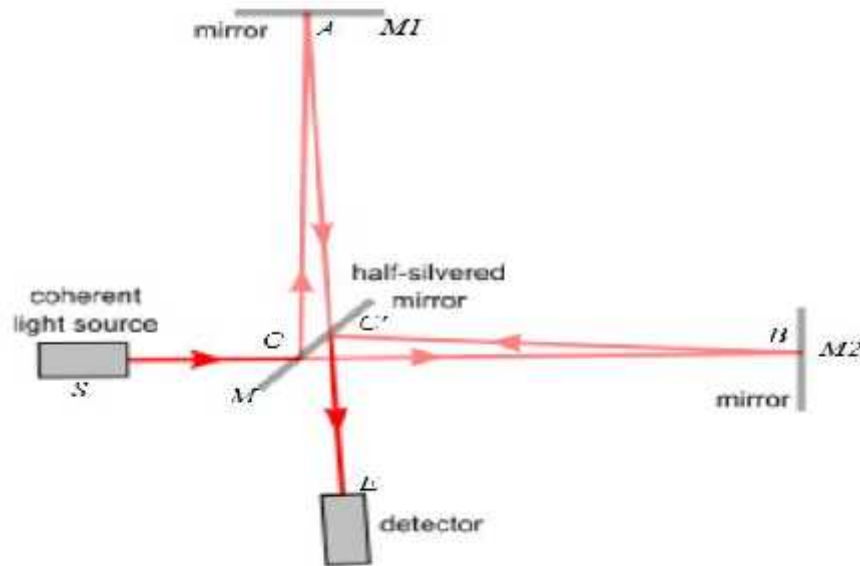

- ❖ The two mirrors are mounted vertically on two arms at right angles to each other. The planes of the mirrors can be slightly tilted with the fine screws at their backs.
- ❖ The mirror M_2 is fixed. The mirror M_1 can be moved parallel to itself by means of a very sensitive micrometer screw. G_1 and G_2 are two plane parallel glass plates of equal thickness.
- ❖ The plate G_1 is semi-silvered on the back side. G_1 is a beam splitter; i.e., a beam incident on G_1 is partially reflected and partially transmitted. G_1 is inclined at an angle of 45° to the incident beam. G_2 is called the compensating plate. S is a light source.

Working:

- ❖ Light from the source S is rendered parallel by lens L and falls on the glass plate G_1 at an angle of 45° . At the back surface of G_1 , it is partly reflected along AC and partly transmitted along AB .
- ❖ The reflected beam moves towards mirror M_1 and falls normally on it. It is reflected back along the same path and emerges out along AT . The transmitted ray AB falls normally on the mirror M_2 . It is reflected along the same path. After reflection at the back surface of G_1 , it moves along AT .

- ❖ The two emergent beams have been derived from a single incident beam and are, therefore, coherent. The two beams produce interference under suitable conditions.

Function of the compensating plate G_2 :

- ❖ The reflected ray AC passes through G_1 thrice. But the transmitted ray AB passes through G_1 only once. That is why a second plate G_2 of the same thickness and inclination as G_1 is introduced. Thus function of the plate G_2 is only to equalize the optical paths traversed by both the beams.

Types of Fringes :

(i) Circular fringes :

- ❖ Concentric circular fringes are obtained when both the mirrors M_1 and M_2 are mutually perpendicular. The image of M_2 is at M_2' parallel to M_1 (Fig.2.17). Hence, M_2' and M_1 form the equivalent of a parallel varied by moving mirror M_1 parallel to itself.
- ❖ Let the eye or the telescope be set along a direction making an angle r with the normal to M_1 . Then the path difference between the two coherent beams is $2t \cos r$. The condition for a bright ring is $2t \cos r = m\lambda$ where m is an integer. The condition for a dark ring is $2t \cos r = (2m-1) \lambda/2$. In either case, r will be constant for given values of t , n and λ .
- ❖ Hence the loci of maxima of intensity will be concentric circles having their centre on the perpendicular from the eye or telescope on M_1 . The circular fringes will be situated at infinity. Therefore they can be observed by a telescope focused for infinity.

(ii) Straight fringes:

- ❖ If M_1 and M_2 are not exactly perpendicular, a wedge shaped air film is formed between M_1 and M_2' . The fringes become practically straight line M_1 actually intersects M_2' in the middle.
- ❖ The fringes are fringes of equal thickness. The fringes are localized in the air film itself. Hence the telescope has to be focused on the film to observe these fringes.

(iii) White light fringes:

- ❖ If white light is used, the central fringes will be dark and others will be colored. With white light, fringes are observed only when the path difference is small. These fringes are important because they are used to locate the position of zero path difference.

Fabry-Perot Interferometer:

Principle:

- ❖ A Fabry-Pérot interferometer (FPI) is typically made of a transparent plate with two reflecting surfaces, or two parallel highly reflecting mirrors. Its transmission spectrum as a function of wavelength exhibits peaks of large transmission corresponding to resonances.

Construction:

This apparatus consists of two glass plates A and B separated by a distance t . Their inner surfaces are optically plane, accurately parallel and thinly silvered. Let a beam of monochromatic light SP from an extended source be incident on the glass plate A of the interferometer as shown below fig.

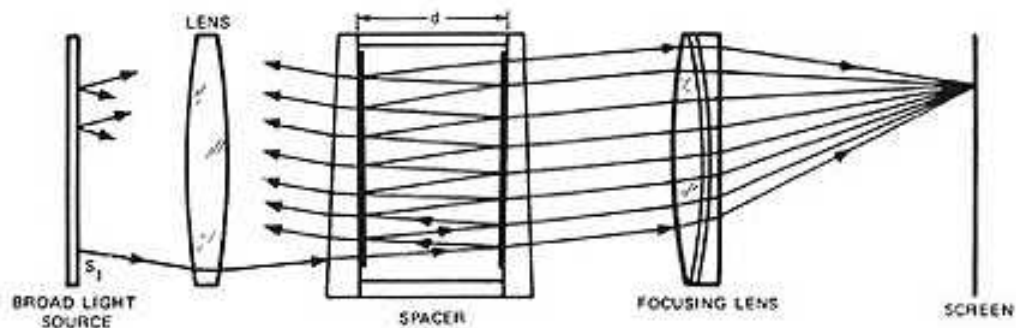

- ❖ The beam suffers multiple reflections in the air film. The parallel transmitted rays are brought to focus at the point S'' by the convex lens L.
- ❖ Let θ be the angle of incidence on the silvered surface of A. The condition for the rays to produce maxima is

$$2t \cos \theta = m\lambda \text{ where } m = 0, 1, 2, 3, \dots \text{etc.}$$

- ❖ The above condition will be satisfied for all points lying on a circle drawn through S'. With O as centre. Hence we shall obtain a bright ring through S'. With change in the value of θ , different orders of concentric rings will be produced.
- ❖ Hence the transmitted rays produce concentric dark and bright rings. The phenomenon is called 'multiple-beam interference'.
- ❖ In the interferometer, one plate is kept fixed. The other plate can be moved to vary the separation of the plates. The Fabry-Perot interferometer is used to determine wavelengths precisely, to compare two wavelengths etc.

Holography:

Principle:

- ❖ When an object is photographed by a camera, the photograph records only the intensity distribution in a particular plane. The details of the field nearer and farther than the focused plane are not recorded.
- ❖ Also the phase distribution which prevailed at the plane of the photograph is lost. Thus the three dimensional character of the object scene is lost and we get only a two-dimensional recording of a three-dimensional scene
- ❖ The principle of holography can best be explained in two steps:
 - (i) Recording of the hologram and (ii) reconstructing the image.

Recording of a Hologram

- ❖ First of all the laser beam is divided into two parts (1 and 2). The second beam illuminates the object. The reflected or scattered beam falls on the photograph plate P. The first beam (reference beam) is reflected onto photographic plate by means of plane mirror M. In this way, the film is exposed simultaneously to reference beam and reflected beam from the object.

- ❖ Since both beams belong to the same laser wave front, the beams interfere on the plate. Thus we obtain a complicated interference pattern on the film. The film is called a hologram.
- ❖ The hologram contains information not only about the amplitude but also about the phase of the object wave. Unlike a photograph, the hologram has little resemblance with the object; in fact, information about the object is coded into the hologram.

Reconstructing:

- ❖ The hologram is used to produce the real and virtual image of the object. The hologram is illuminated by a single beam from laser, called the reconstruction wave. This reconstruction wave is identical in wavelength to the reference wave used for recording the hologram.
- ❖ When the hologram is illuminated by the reconstruction wave, two waves are produced. One wave appears to diverge from the object and provides the virtual image of the object.
- ❖ The second wave converges to form a second image which is real and thus can be recorded on a screen or photographed.

UNIT – II

DIFFRACTION AND OPTICAL INSTRUMENTS

Introduction:

- ❖ This shows that light travels in straight lines, if, however the size of the obstacle is small, (comparable to the wavelength of light), there is a departure from straight line propagation and the light bends into the geometrical shadow.
- ❖ This phenomenon of bending of light waves around corners and their spreading into the geometrical shadow of an object is called diffraction.
- ❖ There are two kinds of diffraction:
 - i) Fresnel diffraction and
 - ii) Fraunhofer diffraction

i) Fresnel diffraction:

- ❖ In this case, either the source or the screen or both are at finite distances from the diffracting aperture or the obstacle (Fig.).

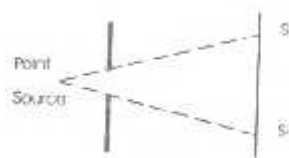

- ❖ No lenses are used to make the rays parallel or convergent. The waveforms are either spherical or cylindrical.

ii) Fraunhofer Diffraction:

- ❖ In this case, the source and the screen are at infinite distances from the aperture. This is achieved by placing the source and the screen in the focal planes of two lenses (Fig.)

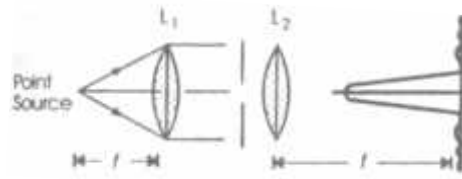

- ❖ L_1 make the light beam parallel. L_2 makes the screen receive a parallel beam of light. Thus the two lenses effectively move the source and screen to infinity. The incident wave front is plane.

Fresnel's Explanation of rectilinear propagation of light:

Construction of half-period zones:

- ❖ Let ABCD be a plane wave front of monochromatic light of wavelength λ . It is traveling from O to P. We want to find the effect of the wave front at an external point P.

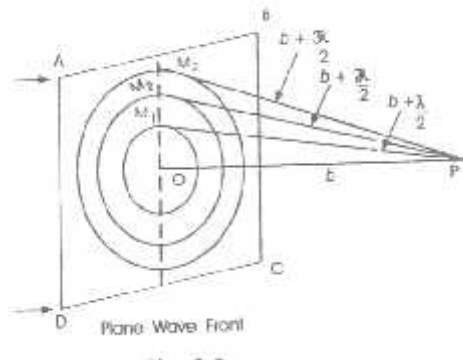

- ❖ Fresnel subdivided the wavefront ABCD into a number of h.p zones. From the point P, drop a perpendicular PO on the wavefront. Let PO = b, O is known as pole w.r.t point P. With P as centre .

$$b + \frac{\lambda}{2}, b + \frac{2\lambda}{2}, b + \frac{3\lambda}{2}, \dots, b + \frac{n\lambda}{2}$$

- ❖ These spheres intersect the wave front ABCD along concentric circles with O as a centre. $OM_1, OM_2, OM_3, OM_{n-1}, OM_n$ etc., are the radii of the circles . The area enclosed by the first circle of radius OM_1 is called the second h.p zone and so on .

Radii of h.p zones: The radius of the nth h.p zone is

$$OM_n = r_n = \sqrt{\left(b + \frac{n\lambda}{2}\right)^2 - b^2} \approx \sqrt{nb\lambda}$$

- ❖ Thus we see that the radii of half period zones are proportional to the square roots of the natural numbers.

Area of a h.p. zone: Area of the nth h.p zone

$$= f(OM_n)^2 - f(OM_{n-1})^2 = f(nb) - f(n-1)b = fb$$

- ❖ The area of the nth zone is independent of n. Thus the area of each h.p zone is approximately the same.

The amplitude of the disturbance at P due to a given zone is ,

- Directly proportional to the area of the zone ,
- Inversely proportional to the distance of the point P from the given zone and,
- Directly proportional to the obliquity factor ($1+\cos\theta$).

The zone plate:

Principle:

- ❖ It is a specially constructed diffraction screen such that light from every alternate zone is cut off. The resultant amplitude at a point P is

$$A = d_1 - d_2 + d_3 - d_4 + d_5 - \dots$$

Here d_1, d_2, d_3 etc., are the amplitudes at P due to first, second, third,.....h.p zones .

- ❖ Now if the light is obstructed from even h.p zones, then the resultant amplitude at P is

$$A = d_1 + d_3 + d_5 + \dots$$

If the light is obstructed from odd h.p zones,

$$A = - (d_2 + d_4 + d_6 + \dots)$$

In either case the amplitude and hence the intensity at P is enormously increased.

- ❖ Now, the radius of nth h.p zone is $r_n = \sqrt{nb}$
- ❖ Therefore the radii of successive h.p. zones are in the ratio $1:\sqrt{2}:\sqrt{3}:\sqrt{4}$ etc., this principle is used in the construction of zone plate. It is a simple device for focusing light rays by diffraction.

Construction:

- ❖ A large number of concentric circles with radii proportional to the square roots of natural numbers are drawn on a sheet of white paper. The odd numbered zones are painted black. A highly reduced size photograph of this pattern is taken on a thin glass plate.
- ❖ In the negative of the photograph, the odd zones, which were painted back, appear transparent and the even zones appear black (Fig.). The resulting glass negative is called positive zone plate.

Theory:

- ❖ S is a point source of monochromatic light giving out spherical waves of wavelength λ (Fig). AB represents a positive zone plate. The source is placed on the axis at a distance a from the Centre O of the zone plate.
- ❖ P is a point on the screen at a distance b from O. let us find the intensity of light at P due to the wave front coming from S. with O as centre and radii $OM_1 = r_1$, $OM_2 = r_2$ $OM_n = r_n$., divide the plate AB into h.p. zones . From one zone to the next , there is an increasing path difference of $\lambda/2$. Hence ,

$$SM_1 + M_1P = SO + OP + \lambda/2$$

$$SM_2 + M_2P = SO + OP + 2\lambda/2$$

$$SM_n + M_nP = SO + OP + n(\lambda/2) \quad \text{--- (1)}$$

To find the radius r_n of the nth zone : Let $SO = a$ and $OP = b$.

$$SM_n = \sqrt{(SO^2 + OM_n^2)} = (a^2 + r_n^2)^{\frac{1}{2}} = a \left(1 + \frac{r_n^2}{a^2} \right)^{\frac{1}{2}}$$

$$\therefore SM_n = a + \frac{r_n^2}{2a} \quad (\because r_n \ll a)$$

Similarly, $M_nP = b + \frac{r_n^2}{2b}$

Substituting these values in eq(1), namely

$$SM_n + M_nP = SO + OP + n(\lambda/2),$$

we have $a + \frac{r_n^2}{2a} + b + \frac{r_n^2}{2b} = a + b + n(\lambda/2)$

$$r_n^2 \left(\frac{1}{a} + \frac{1}{b} \right) = n \quad \text{or} \quad r_n^2 = \left(\frac{ab}{a+b} \right) n \quad \text{--- (2)}$$

$$\therefore r_n \propto \sqrt{n} \quad (\because a, b \text{ and } \} \text{ are constants})$$

- ❖ Thus the radii of the various zones are proportional to the square roots of natural numbers.

The area of the nth zone .

$$= f r_n^2 - f r_{n-1}^2 = f \left[\frac{n \} ab}{a+b} - \frac{(n-1) \} ab}{a+b} \right] = f \frac{\} ab}{a+b} \quad \text{--- (3)}$$

- ❖ The area is independent of n. hence the area of all the zones is the same. But the distance of the zone from P and the obliquity increase as the order of the zone increases.
- ❖ Hence , the amplitude at P due to a zone decreases as the order of the zone increases. Let d_1, d_2, d_3, \dots be the displacements at p due to the first , second, third, etc., zones . Then , the resultant amplitude at P is

$$A = d_1 + d_3 + d_5 + \dots$$

- ❖ This displacement A is enormously greater than $d_1/2$, the resultant due to all zones . Hence the point P is extremely bright . P can be said to be the image of S. this explains the focusing action of a zone plate . It thus behaves like a convex lens .

Focal length :

Eq(2) can be written as $\frac{1}{a} + \frac{1}{b} = \frac{n \} }{r_n^2}$

Applying the sign convention , $\frac{1}{b} - \frac{1}{a} = \frac{n \} }{r_n^2}$ ---(5)

This is similar to the convex lens formula $\frac{1}{v} - \frac{1}{u} = \frac{1}{f}$ --- (6)

With a and b as the object and image distances,

therefore $f = \frac{r_n^2}{n \} }$ --- (7)

Here , f is called the primary or first order focal length of the zone plate , thus the zone plate acts as a convergent lens .

Comparison of a zone plate with a convex lens:

Similarities:

(1) The distances of the object and image are connected together by similar formulate in both cases.

$$\text{Convex lens : } \frac{1}{v} - \frac{1}{u} = \frac{1}{f} \text{ ; zone plate : } \frac{1}{b} - \frac{1}{a} = \frac{n}{r_n^2}$$

(2) Focal length of both varies with the wavelength λ . Hence both show chromatic aberration.

Differences:

- ❖ A convex lens has only one focus. But a zone plate has several foci.
- ❖ The rays are brought to focus by refraction in a convex lens. But the image is formed by diffraction in a zone plate.
- ❖ The image due to a convex lens is more intense than that due to a zone plate.
- ❖ In a zone plate $f_r < f_v$ since $f = \frac{r_n^2}{n\lambda}$ and $\lambda_r > \lambda_v$. But in case of lens $f_r > f_v$.
- ❖ In the case of a convex lens, all the waves meet in a phase the image, after traversing the same optical path. But in the zone plate, the waves travel unequal optical paths. The rays from two successive transparent zones differ in path by λ .

Phase contrast Microscope:

Principle:

- ❖ Suppose that the object is completely transparent but has an optical thickness which varies from point to point. Such an object is called a phase object. IT introduces phase differences between disturbances which pass through different parts of it.
- ❖ Consequently, the disturbances in the conjugate image plane have the same amplitude at all points but will show variations in phase from point to point.
- ❖ The eye can distinguish only changes in intensity but not changes in phase. To see a small transparent object, it is necessary to magnify it and also to convert differences in phase into differences in intensity. Zernike in 1935 introduced the concept of phase contrast.

- ❖ Consider a beam of light passing through a transparent plate of varying thickness. The amplitude vector at the points A, B, C has the same magnitude but is in different directions (Fig.).

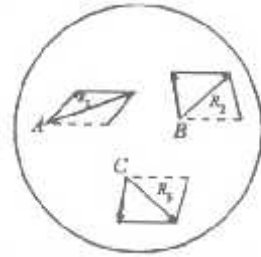

- ❖ The intensity is the same at all points but there are differences in phase between the vectors. If a constant phase plate (represented by the dotted vectors), the resultant amplitudes at the points A, B and C are R_1 , R_2 respectively. Their magnitudes are different.
- ❖ Hence the intensities are different and can be seen by the eye. The variations in optical thickness in the object cause variations in intensity in the image. This method of converting differences in phase into differences in intensity is employed in phase-contrast microscope.

Plane Transmission Diffraction Grating

- ❖ *An arrangement consisting of large number of parallel slits of equal width and separated from one another by equal opaque spaces is called a diffraction grating.*
- ❖ It is constructed by ruling equidistant parallel lines with a fine diamond point on an optically plane glass plate. The ruled lines are opaque to light. These are called opacities.
- ❖ The space in between any two lines is transparent to light. The spaces are called the transparencies. Such a grating is called transmission grating.

Theory:

- ❖ Consider a parallel beam of light incident normally on a grating XY (Fig.). AB, CD, EF... are the transparent slits. Let the width of each slit be a and the width of each opaque portion be b .

- ❖ Then the distance $(a+b)$ is called the grating constant or grating element.
- ❖ The points in the consecutive slits separated by the distance $(a+b)$ are called the 'corresponding points'.

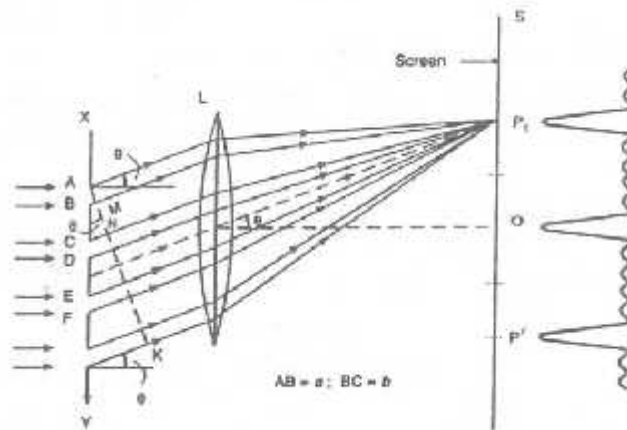

- ❖ Suppose a telescope with its axis normal to the grating is placed in the path of diffracted light. Then the rays issuing out normally are brought to focus at a point O lying on the principal axis of the lens L . All the rays reaching O are in phase with each other. Hence the rays reinforce producing a central bright band (central maximum).
- ❖ The rays diffracted at an angle θ with the grating normal reach P_1 on passing through the lens in different phases. Draw AK perpendicular to the direction of the diffracted light.
- ❖ Then CN is the path difference between the rays diffracted from the two corresponding points A and C at an angle θ .
The path difference $CN = AC \sin \theta = (a+b) \sin \theta$.
- ❖ If the path difference is an even multiple of $\lambda/2$, then the point P will be bright. Hence for maximum intensity, we have

$$(a+b) \sin \theta = \pm n\lambda$$

Where n is an integer, $0, 1, 2, 3$, etc. n is called the order of the interference maximum.

The point P will be dark if $(a+b) \sin \theta = \pm (2n+1)\lambda/2$.

- ❖ Thus the diffracted rays from any pair of corresponding points of the slits will produce constructive or destructive interference at a point P according as the path difference is an even or odd multiple of $\lambda/2$.

- ❖ This condition holds true for all the rays from the corresponding points of any pair of adjoining slits in the entire grating surface. We find therefore that brightness and darkness are alternate.

For $n = 0$, we get central maximum at O . When $n = 0$, $\sin \theta = 0$ and $\theta = 0$. Hence, when there is no diffraction, the light travels straight and is said to be of zero order.

$$\text{For } n = \pm 1, \sin \theta_1 = \pm \frac{\lambda}{(a+b)}$$

- ❖ This gives the condition for the first order principal maximum intensity point on either side of O , i.e., at P_1 and P' . The intensity at P_1 is less than the intensity at O .

$$\text{For } n = \pm 2, \sin \theta_2 = \pm \frac{2\lambda}{(a+b)}$$

This gives the direction of the second order principal maxima.

$$\text{For } n = \pm 3, \sin \theta_3 = \pm \frac{3\lambda}{(a+b)}$$

- ❖ This gives the *III* order principal maximum and so on. Let monochromatic light be incident normally on a grating. Then there will be a central bright image of the source with bright images on either side corresponding to different orders.
- ❖ Let white light be incident normally in a grating. Then the central image is white, since for $n=0$, we have $\theta=0$ irrespective of λ .

Absent Spectra with a Diffraction Grating:

The condition for the n th order principal maximum of a diffraction grating is

$$(a+b) \sin \theta = n\lambda \quad \dots(i)$$

- ❖ Suppose for a given direction θ the path difference between the diffracted rays from the two extreme ends of one slit is equal to an integral multiple of λ . For example, let this path difference be λ .

❖ Then the slit can be imagined to be divided into two halves. The path difference between any pair of corresponding points in the two halves will be $\lambda/2$. This will result in zero intensity in that direction.

❖ Thus the condition for a minimum for a single slit is given by

$$a \sin \theta = p \lambda \quad \dots(ii)$$

where $p = 1, 2, 3, \dots$ excluding zero.

❖ When the conditions (i) and (ii) are simultaneously obeyed, the beams from all the slits reinforce each other but the resultant intensity is zero. Hence the spectrum will be absent.

Dividing (i) by (ii) we get $\frac{a+b}{a} = \frac{n}{p} \quad \dots(iii)$

This is the condition for the n th order spectrum to be absent in the diffraction pattern.

Let $b = a$. Then from Eq. (iii), $n = 2p$.

So the 2nd, 4th, 6th, etc., orders of the spectrum will be missing corresponding to the minima due to a single given by $p = 1, 2, 3$, etc.

Also when $b = 2a$, $n = 3p$.

So the 3rd, 6th, 9th, etc., orders of the spectrum will be missing corresponding to the minima due to a single given by $p = 1, 2, 3$, etc.

Overlapping of Spectral Lines:

❖ Suppose the light incident on the grating surface consists of a large range of wavelengths. Then, the spectral lines of shorter wavelength and of the order overlap on the spectral lines of the longer wavelength and of lower order.

❖ Thus the third order red line ($\lambda = 420 \text{ nm}$) will all occur in the same direction θ because

$$(a+b) \sin \theta = 3 \times 700 \times 10^{-9} = 4 \times 525 \times 10^{-9} = 5 \times 420 \times 10^{-9}$$

❖ The visible region of the spectrum extends from 400 nm to 720 nm. If a photographic plate is employed for observations, then the spectrum may extend down to 200 nm in the ultraviolet region.

❖ Then, a line of 400 nm in the first order will overlap a line of 200 nm in the second order. The overlapping of different wavelengths can be

avoided by the use of suitable filters to absorb those undesired wavelengths which may overlap.

Resolving Power of Optical Instruments:

- ❖ The capacity of an instrument to show two close things separately is called 'resolution'. The ability of an optical instrument to produce distinctly separate spectral lines of light having two or more wavelengths very close to each other or to resolve the images of two nearby points is called its resolving power.

Rayleigh's criterion for resolution:

Rayleigh proposed the following criterion for resolution:

- ❖ Two spectral lines of equal intensities are just resolved by an optical instrument when the principal maximum of the diffraction pattern due to one falls on the first minimum of the diffraction pattern of the other.
- ❖ Consider the intensity distribution curves of two wavelengths λ and $\lambda + d\lambda$ (Fig).

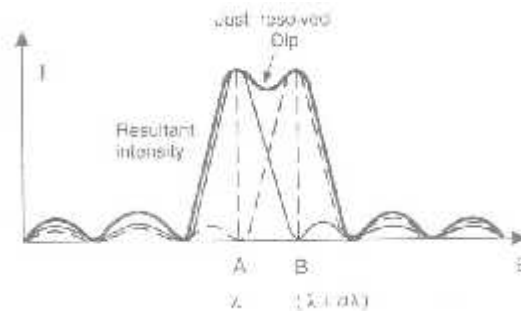

- ❖ The principal maximum of one coincides with the first minimum of the other. The resultant intensity curve shows a distinct dip in the middle indicating the presence of two different wavelengths. The lines are said to be 'just' resolved.
- ❖ A grating or a prism us spectral resolution. If an optical instrument 'just' resolves two spectral lines of wavelengths λ and $\lambda + d\lambda$, then $\lambda/d\lambda$ is a measure of the resolving power' of the instrument.

Resolving Power of a Telescope:

- ❖ The telescope is used to see distant objects. Therefore, the amount of details which the telescope reveals depends on the angle subtended at its objective by the two point objects.
- ❖ The RP of a telescope is therefore defined as the reciprocal of the smallest angle subtended at the objective by the two distant object points which can be just seen as separate ones through the telescope.
- ❖ Let D be the diameter of the telescope objective AB (Fig.)

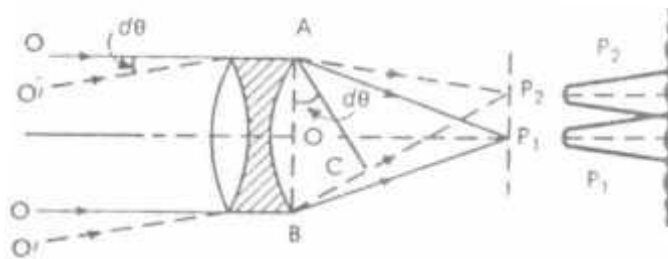

- ❖ Two distant point objects O and O' subtend an angle $d\theta$ at the objective. The image of each object is a diffraction pattern. P_1 and P_2 are the positions of the central maxima of the two images. According to Rayleigh, the objects O and O' will be just resolved when the central maximum of the diffraction pattern of one coincides with the first minimum of the diffraction pattern of the other.
- ❖ The path difference between AP_1 and BP_1 is zero. Hence they reinforce with one another at P_1 . Thus P_1 corresponds to the position of the central maximum of the first image. Let $\angle P_2AP_1 = d\theta$.

The path difference between BP_2 and $AP_2 = BC$

Consider ΔABC .

$$BC = AB \sin d\theta = AB \cdot d\theta = D \cdot d\theta \text{ for small angles)}$$

- ❖ If $D \cdot d\theta = \lambda$ then P2 corresponds to the first minimum of the first image. But P2 is also the central maximum of the second image. Thus, Rayleigh's condition of resolution is satisfied if

$$D \cdot d\theta = \lambda \text{ or } d\theta = \lambda/D$$

This condition holds good for rectangular apertures.

For circular apertures, Airy showed that

$$d\theta = 1.22(\lambda/D)$$

The reciprocal of $d\theta$ measures the RP of the telescope.

$$\therefore \text{RP} = \frac{1}{d\theta} = \frac{D}{1.22\lambda}$$

- ❖ RP depends upon the diameter of the objective and the wavelength of light used. $\text{RP} \propto D$ and $\text{RP} \propto 1/\lambda$. Hence RP can be increased by using objectives of large diameters.

Let r be the radius of the first dark ring and f , the focal length of the objective. Then,

$$d\theta = \frac{r}{f} = \frac{1.22\lambda}{D} \quad \text{or} \quad r = \frac{1.22\lambda f}{D}$$

Eq. (4) shows that if f and λ are small, and D is large, then the radius of the central bright disc is small.

- ❖ Thus, the diffraction pattern will appear sharper and the angular separation $d\theta$ between two just resolvable point objects will be smaller. So the RP of the telescope will be higher.

Resolving Power of a Microscope:

- ❖ The resolving power of a microscope represents its ability to form distinctly separate images of two objects lying close together. It is measured by the smallest distance between two point-objects whose images are just resolved by the objective of the microscope. The smaller is the distance, the higher is the RP.
- ❖ Consider two point objects O and O' (Fig. 3.33).

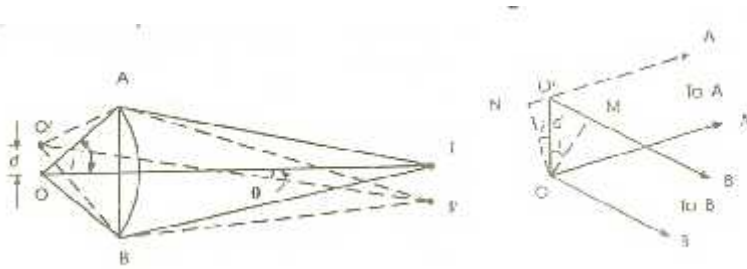

- ❖ The linear distance between O and O' = d.I and I' are the images of O and O; formed by the objective AB of the microscope. The images are actually Fraunhofer diffraction patterns consisting of a central of the discs lie at I and I'.
- ❖ According to Rayleigh's criterion, O and O' will be just resolved if the position of the central maximum of I also corresponds to the first minimum of I'. Airy has shown that this will happen when the path difference between the extreme rays, O'BI - O'AI, is given by

$$O'BI - O'AI, - 1.22\lambda.$$

But the paths AI and BI are equal. Hence the above condition becomes

$$O'B - O'A, - 1.22\lambda.$$

and O' are very close together. Hence, we can take O'A to be parallel to OA, and O'B parallel to OB. From Fig.3.34,

$$O'B - OB = O'M = d \sin i$$

$$\text{and } O'A - OA = O'N = d \sin i$$

Now, OA - OB. Adding Eqs. (2) and (3), $O'B - O'A = 2d \sin i$

Here, i is the semi-vertical angle of the cone of rays received by the objective from O. Now, Eq.(1) becomes,

$$2d \sin i = 1.22 \lambda \text{ or } d = \frac{1.22f}{2 \sin i}$$

- ❖ If the space between the object and the objective is filled with and oil of refractive index n, then

$$d = \frac{1.22\lambda}{2n \sin i}$$

n sin i is called the numerical aperture of the objective of the microscope.

$$\therefore d = \frac{1.22\lambda}{2N.A}$$

This measures the limit of resolution of the microscope. Its reciprocal is called as resolving power.

Resolving Power of a Plane Diffraction Grating :

- ❖ The R.P. of a grating is defined as its ability to show two neighboring lines in a spectrum as separate. It is measured by the ratio $\lambda/d\lambda$, where λ is the wavelength of a spectral line and $d\lambda$ is the least difference in the wavelengths of two neighboring spectral lines which can just be resolved.

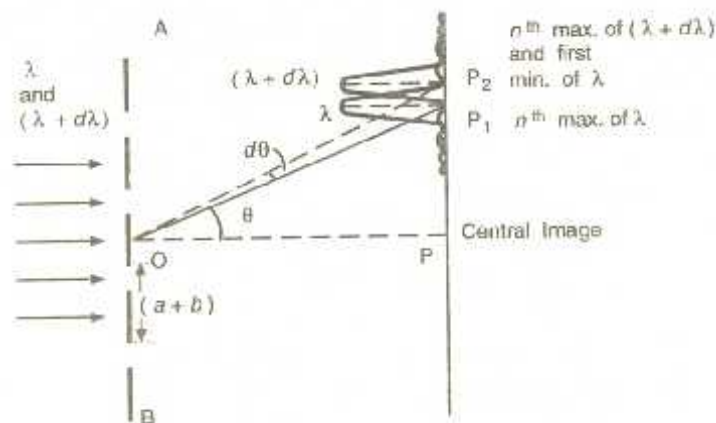

- ❖ In Fig. light of two wavelengths λ and $(\lambda + d\lambda)$ is incident normally on the surface of a plane transmission grating AB. The light of each wavelength would form line of wavelength λ at an angle of diffraction θ . Then,

$$(a+b) \sin \theta = n\lambda$$

Here, $(a+b)$ is the grating element.

- ❖ P2 is the n th primary maximum of a second spectral line of wavelength $(\lambda + d\lambda)$ at an angle of diffraction $(\theta + d\theta)$. Then,

$$(a+b) \sin(\theta + d\theta) = n(\lambda + d\lambda)$$

- ❖ According to Rayleigh, the two spectral lines will appear just resolved if the principal maximum due to $(\lambda+d\lambda)$ falls on the first minimum of λ or vice versa. Thus, the two lines will appear just resolved if the angle of diffraction $(\theta+d\theta)$ also corresponds to the direction of first secondary minimum after the n th primary maximum at P1 corresponding to wavelengths λ .
- ❖ This is possible if the extra path difference introduced is λ/N . Here, N is the total number of lines in the grating.

$$(a+b) \sin(\theta+d\theta) = n\lambda + \lambda/N$$

Equating the right hand sides of Eqs. (2) and (3),

$$n(\lambda+d\lambda) = n\lambda + \lambda/N \quad \text{or} \quad n d\lambda = \lambda/N \quad \therefore \lambda/d\lambda = nN$$

The R.P. increases with

- (i) the order n of the spectrum.
- (ii) the total number of lines N on the grating. The R.P. is independent of the grating element $(a+b)$.

UNIT-III

POLARIZATION

Nicol Prism Polarizer and Analyzer:

Principle:

- ❖ It is an optical device made from a calcite crystal. It is used for producing and analysing plane polarised light. Its action is based on the phenomenon of *double refraction*.
- ❖ When a ray of ordinary unpolarised light is passed through a calcite crystal, it is split up into the o-ray and the e-ray. Both these rays are plane polarised.
- ❖ In Nicol prism, o-ray is eliminated by total internal reflection. Hence only e-ray is transmitted through the prism. The e-ray is plane polarised and has its vibrations parallel to the principal section.

Construction:

- ❖ A calcite crystal ABCD (Fig.)

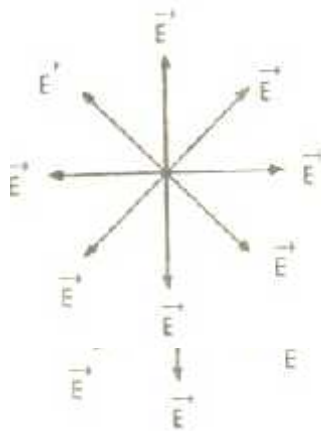

- ❖ whose length is 3 times its breadth is taken. Its end faces AB and CD are ground such that the angles in the principal section become 68° and 112° instead of 71° and 109° . The crystal is then cut apart along the plane A'D perpendicular to both the principal section and the end faces A'B and CD'.
- ❖ The two cut surfaces are ground and polished optically flat. They are then cemented together by Canada balsam which is a transparent

liquid of refractive index 1.55 for sodium light. The crystal is then enclosed in a tube blackened inside.

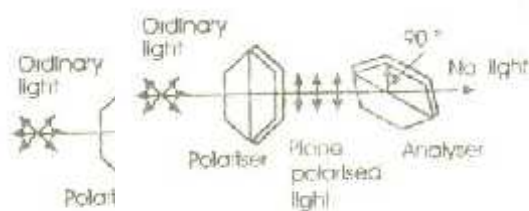
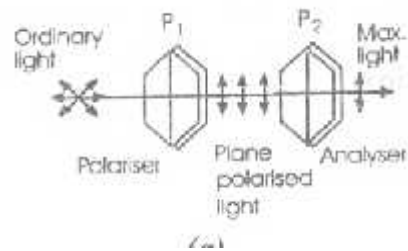

- ❖ A ray KL of unpolarised light nearly parallel to BD' is incident on the face A'B. The ray is split up into an O-ray LM and an E-ray LN. The cutting is such that the O-ray is incident on the Canada balsam surface at an angle greater than the critical angle and is totally reflected sideways.
- ❖ The sides of the prism are blackened to absorb the O-ray. The E-ray travels from an optically rarer medium to a denser medium. Therefore it is transmitted through the prism.
- ❖ This E-ray is plane polarised and has vibrations in the principal section parallel to the shorter diagonal of the end face of the crystal. Thus we get a single beam of plane polarised light. So the Nicol prism can be used as a polariser.

Limitation:

- ❖ A parallel beam of light, parallel to the longer side of the prism should be used. Otherwise all the O-rays will not fall on the Canada balsam surface at an angle greater than the critical angle and some of the O-rays may also be transmitted.

- ❖ So the light emerging from the Nicol prism will not be plane polarised. Calculation shows that if the beam is convergent or divergent, the semi-angle of the cone should not be more than 14° with the axis of the cone parallel to the longer side.

Uses:

- ❖ Nicol prism can be used both as a polarizer and an analyzer. Consider two Nicol's arranged coaxially (Fig.). The first Nicol which produces the plane-polarized light is called the polarizer. The second Nicol which analyses the polarized light is called the analyzer.
- ❖ When the two Nicols are placed with their principal sections parallel to each other as in Fig. Then the E-ray transmitted by one is freely transmitted by the other. This position and the other position corresponding to the Angle of 180° between the two principal sections is known as parallel Nicols.
- ❖ The intensity of emergent light in these settings is maximum. On rotating one of the two Nicols, the intensity of the transmitted light decreases. When the principal sections of the two Nicols are mutually perpendicular, no light is transmitted by the system. It is so because the E-ray from the first Nicol forms an O-ray, for the second and is, therefore, totally reflected. The two Nicols are said to be crossed in this position.
- ❖ Let I_0 be the intensity of transmitted beam when the principal sections of the two Nicols are parallel. Let I_θ be the intensity when the principal sections are inclined at an angle θ . Then according to Malus law,

$$I_\theta = I_0 \cos^2 \theta .$$

- ❖ The above facts can be used for detecting plane polarized light. If the given light on examination through a rotating Nicol shows a variation in intensity with minimum intensity zero, the given light is plane polarized.

Dichromic Polarizer:

- ❖ There are certain crystals and minerals which are doubly refracting and have the property of absorbing the ordinary and the extraordinary rays unequally. In this way, plane polarized light is produced.
- ❖ The crystals showing this property are said to be dichroic and the phenomenon is known as dichroism.
- ❖ Tourmaline is a dichroic crystal and absorbs the ordinary ray completely as shown in Fig.

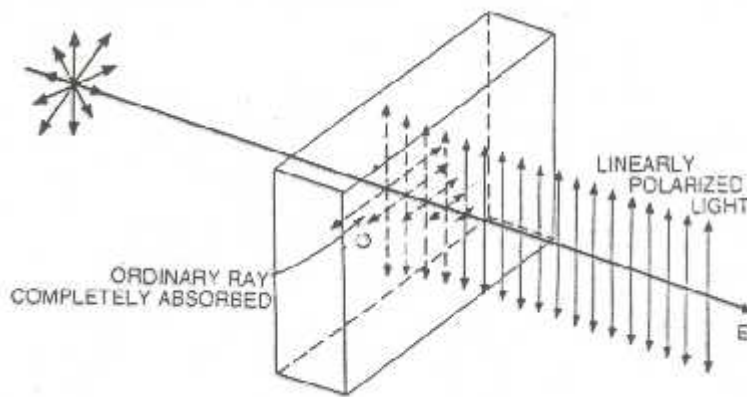

- ❖ The ordinary ray is completely absorbed while the extraordinary ray is partly absorbed and so it emerges.
- ❖ Herapathite crystals are embedded in a volatile viscous medium and the crystals are aligned with their optic axes parallel. They are prevented from shattering. There are a number of methods of preparing polaroid sheets.
- ❖ In one process, the dichroic crystals are embedded and arranged with their optic axes parallel in cellulose acetate. A more recent type is prepared by taking a sheet of polyvinyl alcohol and subjecting it to a large strain. In this way, the molecules are oriented parallel to the strain and the material becomes doubly refracting. It acts as a dichroic crystal when strained with iodine.
- ❖ The polaroid sheets are placed between glass plates so that they are not spoiled. When the two pieces of polaroid's are uncrossed, the

emergent beam is plane polarized, Fig. When the two polaroids are crossed, there is perfect extinction of light.

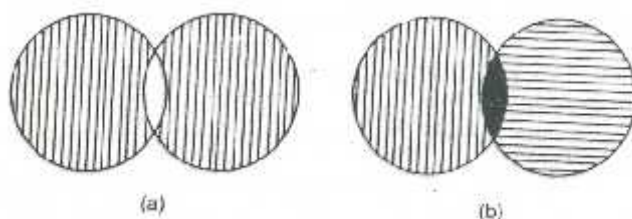

Uses of Polaroids:

- ❖ Polaroids are widely used as polarizing sun glasses. Polaroid films are used to produce three-dimensional moving pictures. They are used to eliminate the head light glare in motor cars.
- ❖ They are also used to improve the colour contrasts in old oil paintings and as glass window in trains and aero planes. In aero plans, one of the Polaroid's is fixed while the other can be rotated to control the amount of light coming inside.

Huygen's theory of double refraction in uniaxial crystals:

Huygens extended his principle of secondary wavelets to explain double refraction. He assumed:

- i. When a beam of light strikes the surface of a doubly refracting crystal, each point on the surface becomes the origin of two wave fronts which spread out into the crystal. One wave front is for D-ray and the other is for E-ray. In other words, the wave surface is double.
- ii. For the D-ray, the crystal is isotropic. So the D-ray travels with the same velocity in all directions. Hence the wave front (or wave surface) corresponding to a-ray is spherical.
- iii. For the E-ray, the crystal is anisotropic. So for the E-ray, velocity varies with direction. Hence the wave front (or wave surface) is a spheroid (ellipsoid of revolution).

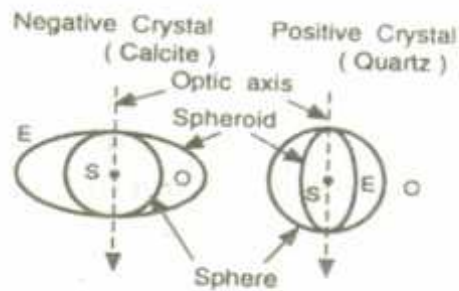

- iv. The sphere and the spheroid touch at two points. The line joining them is called the optic axis.
- v. Consider a point source of light S within the crystal. D and E are the wave surfaces for the O -ray and E -ray. In a negative crystal, the ordinary wave-surface (sphere) lies within the extraordinary wave-surface (spheroid). In a positive crystal, the ordinary wave-surface (sphere) lies outside the extra-ordinary wave-surface (spheroid).

Double-image Polarizing Prisms

- ❖ Nicol prism cannot be used in ultra-violet light because Canada balsam layer absorbs these radiations. Moreover, in Nicol prism only the E -ray is transmitted while O -ray is lost by total internal reflection. Sometimes it is desirable to have both the rays in order to obtain two widely separated images.
- ❖ This can be achieved by optical devices known as double-image prisms. There are two such prisms: the Rochon prism and the Wollaston prism.

Rochon prism:

- ❖ It consists of two right-angled prisms ABC and ADC of quartz cemented together with glyceride or castor oil so as to form a rectangular block.

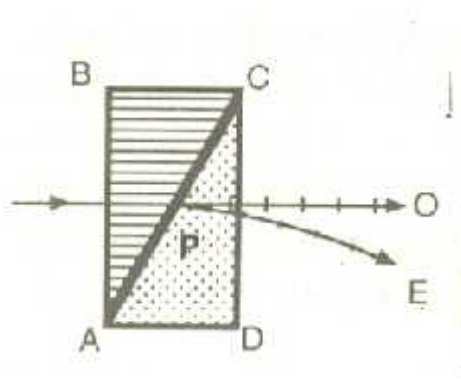

- ❖ The optic axis of the prism ABC is in the plane of incidence and perpendicular to the refracting edge i.e., parallel to its base BC. The prism ADC has its optic axis perpendicular to the plane of incidence (i.e. perpendicular to the plane of the paper) and parallel to the refracting edge.
- ❖ A ray of light incident normally on the face AB travels undeviated along the optic axis of the first prism. On entering the second prism ADC at P, it split up into O and E-rays.
- ❖ The O-ray travels un-deviated, thus remaining achromatic. The E ray is both deviated and dispersed. When only one plane-polarised ray is required the E-ray on account of its deviation can be cut off.

Wollaston prism:

- ❖ It consists of two prisms ABC and ADC of quartz cut in such a way that the optic axis of ABC lies in the plane of incidence and is parallel to the face AB. The optic axis ADC is perpendicular to the plane of incidence. Both the prisms are cemented together by glycerin or castor oil.
- ❖ The incident ray entering normally to the surface AB travels perpendicular to the optic axis.

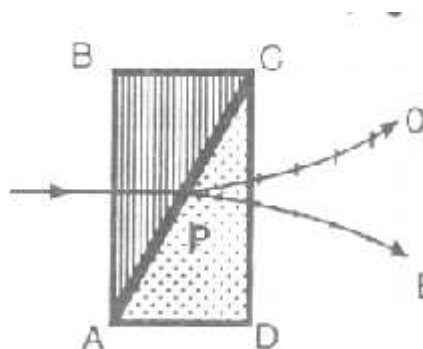

- ❖ Therefore, the *O* and *E*-rays travel in the first prism in the same direction but with different velocities. The second prism is cut with its optic axis perpendicular to that of the first. So the *O*-ray in the first prism becomes the *E*-ray in the second and vice-versa.
- ❖ Hence both the rays are deviated and dispersed in the second prism resulting in greater and greater separation of the two rays. The prism is especially useful in determining the percentage of polarization in a partially polarized beam.

Quarter Wave Plate:

- ❖ A plate of doubly refracting uniaxial crystal cut with its optic axis parallel to the refracting faces and capable of producing a path difference of $\lambda/4$ (or a phase difference of $\pi/2$) between the ordinary and extraordinary waves is called a 'quarter wave plate'.

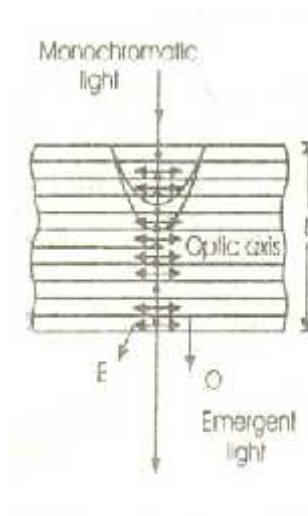

- ❖ Consider a plate of doubly refracting uniaxial crystal cut with its faces parallel to the optic axis. A beam of mono-chromatic light of wavelength λ is incident normally on the plate.
- ❖ It is broken up into *O* and *E* waves inside the plate. Both of these waves travel in the same direction (perpendicular to the faces) but with different velocities.

Let t be the thickness of the plate. The optical paths of the O and E waves in the plate are $n_o t$ and $n_e t$. The path difference between the two waves on emerging

$$= (n_o - n_e) t$$

If $(n_o - n_e) t = \lambda/4$, the plate is called a quarter wave plate.

$$(n_o - n_e) t = \lambda/4 \text{ or } t = \frac{\lambda}{4(n_o - n_e)}$$

For a positive crystal such as quartz, $n_e > n_o$

For a negative crystal such as calcite, $n_o > n_e$

- ❖ If the thickness of the plate is such that $(n_o - n_e) t = (2m + 1) \lambda/4$ where m is an integer, the plate still acts as a Q.W.P.
- ❖ A Q.W.P. is used for producing circularly and elliptically polarised lights. If plane polarised light with its vibrations making an angle of 45° with the optic axis is passed through a Q.W.P., the emergent light is circularly polarised.
- ❖ If, however, the plane of vibrations of the incident plane polarised light is not inclined at an angle of 45° to the optic axis, the emergent light is elliptically polarised.

Half Wave Plate :

- ❖ A plate of doubly refracting uniaxial crystal cut with its optic axis parallel to the refracting faces and capable of producing a path difference of $\lambda/2$ (or a phase difference of π) between O and E rays is called a 'half wave plate'.
- ❖ Let t be the thickness of such a plate. The optical paths for the O and E rays through the crystal are $n_o t$ and $n_e t$.

\therefore the optical path difference between the O and E rays = $(n_o - n_e) t$

This should be equal to $\lambda/2$ for a half wave plate.

$$(n_o - n_e) t = \lambda/2 \text{ or } t = \frac{\lambda}{2(n_o - n_e)}$$

This is the minimum thickness. Any plate which introduces a path difference of $(2m + 1) \lambda/2$ will also act as a half wave plate.

In general,

$$t = \frac{(2m+1)\lambda}{2(n_o - n_e)}$$

$\lambda/4$ and $\lambda/2$ plates are generally called as retardation plates.

Babinet's Compensator:

- ❖ It consists of two quartz-wedges A and B of equal small acute angles. The optic axis of A is at right angles to the refracting edge and that of B is parallel to the refracting edge.
- ❖ Two wedges are placed with their hypotenuses in contact to form a rectangular block. One of the wedges is fixed, while the other can be moved in its own plane by means of a micrometer screw S. The angle of rotation of screw may be read on a graduated circular scale.

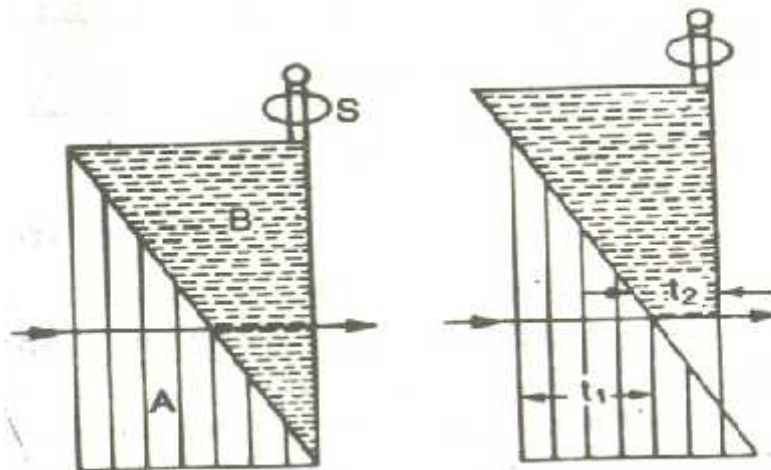

Theory:

- ❖ When plane-polarised light falls normally on the first wedge with its plane of vibration making an angle e with the optic axis, it is broken up into E and O components. As quartz is a positive crystal, the ordinary component travels faster than extra-ordinary component.
- ❖ On entering the second wedge, the E-component becomes the O-component and vice-versa. In other words, the two components

exchange velocities in passing from one wedge to the other. Thus the two wedges tend to cancel each other's effect.

- ❖ Let t_1 , and t_2 be the thicknesses of the two wedges traversed by a particular ray, and n_e and n_o the refractive indices of quartz for the E and O components respectively. Then the path difference introduced between the two components by the first wedge is $t_1(n_e - n_o)$ and that introduced by the second wedge is $- t_2 (n_e - n_o)$. Hence the resultant path difference

$$\Delta = (t_1 - t_2) (n_e - n_o)$$

- ❖ The value of $\Delta = 0$ for $t_1 = t_2$ at the centre of the compensator and emergent light in this region is plane polarised. On either side of this point the path difference gradually increases and the emergent light is polarised in various ways depending on the corresponding values of $(t_1 - t_2)$.
- ❖ By moving the second wedge relative to the first, any value of $(t_1 - t_2)$ can be arranged at the Centre of the compensator. Then this portion can be used as a quarter-wave plate, half-wave plate or a wave plate of any other thickness.
- ❖ Thus, the compensator has an advantage over a quarter-wave plate. The quarter-wave plate produces a path difference of $\lambda/4$ for one particular wavelength, whereas the compensator can be adjusted for any wavelength.

Calibration of compensator:

The experimental arrangement is shown in Fig.

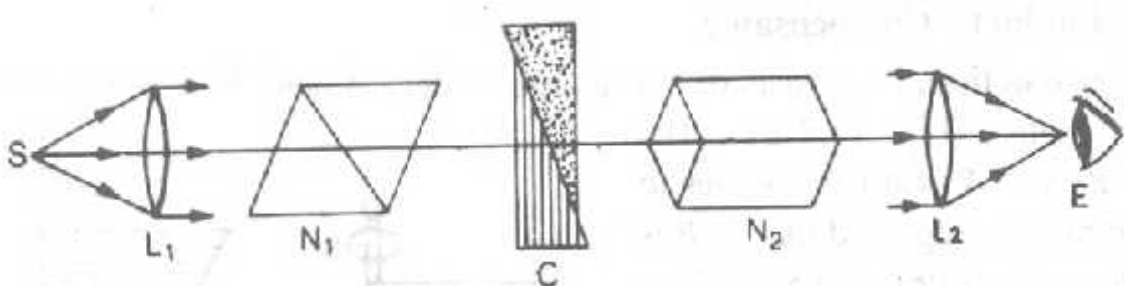

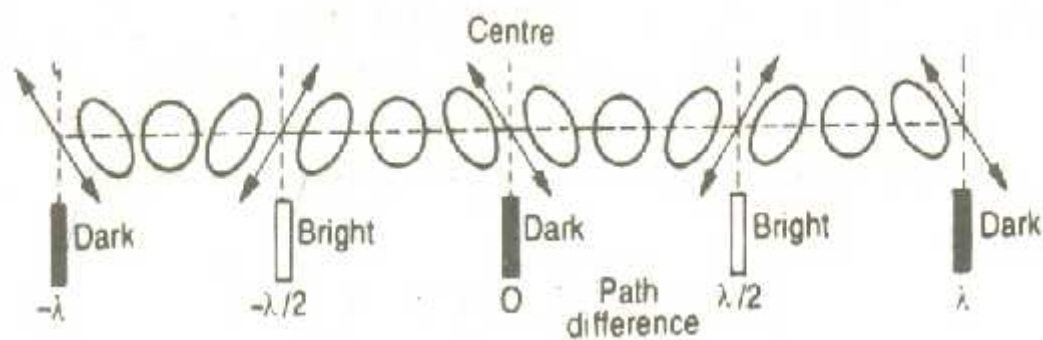

- ❖ The compensator C is placed between two crossed Nicols N_1 , and N_2 (polarizer and analyzer). The polarizer N_1 is so oriented that the plane polarised light emerging from it and falling normally on the compensator makes an angle e with the optic axis of the first edge of compensator.
- ❖ The plane-polarised light traversing those portions of the compensator for which the path difference is $0, \lambda, 2\lambda, \dots, m\lambda$, the emergent light from C is also plane polarised with its plane of vibration parallel to that of incident light. Hence dark bands appear at all such places with equal spacing.
- ❖ For places where $\Delta = \lambda/2, 3\lambda/2, 5\lambda/2 \dots$ the emergent light is plane polarised with vibrations at an angle 2θ with that of the incident light. However if $\theta = 45^\circ$ then $2\theta = 90^\circ$ and N_2 does not stop this light at all and at such places bright equispaced bands appear.
- ❖ The clear-cut appearance of bright and dark bands is indication of such a correct setting. In the intermediate positions the light transmitted by compensator shall be elliptically polarised having different orientations. However with white light the central band shall be dark while others shall be colored.
- ❖ To calibrate the compensator, the movable wedge is displaced with the help of micrometer screw. Now the dark bands move laterally across the field of view. The movable wedge is adjusted in such a way that a

dark band appears on the cross wire. The reading of micrometer screw is noted.

- ❖ The screw is again turned to bring the next dark band on the cross-wire and its reading is again noted.
- ❖ The difference of two readings gives the angle of rotation α of the screw which corresponds to a path difference of λ or a phase difference of 2π . The procedure is repeated for number of bands and mean α is obtained. This calibration is then used to determine following constants of elliptic vibrations.

Production and detection of plane, circularly and elliptically polarised light:

Production of plane polarised light:

- ❖ Generally, a Nicol prism is used for producing plane polarised light. A beam of unpolarized monochromatic light is passed through a Nicol prism. It is split up into *O* and *E* components inside the Nicol.
- ❖ The *O* component is totally reflected at the Canada balsam layer and is absorbed by the blackened sides. The *E* component passes through the end face. It is plane polarised with vibrations in the plane of the paper.

Detection:

- ❖ The beam is allowed to pass through a Nicol prism. The Nicol is rotated gradually about the incident beam as axis. If the intensity of the light varies and light is completely extinguished twice in each rotation of the Nicol, then the beam is plane polarised.

Production of circularly polarised light:

- ❖ Circularly polarised light is produced if the amplitudes of the *O* and *E* rays are equal and there is a phase difference of $\pi/2$ or a path

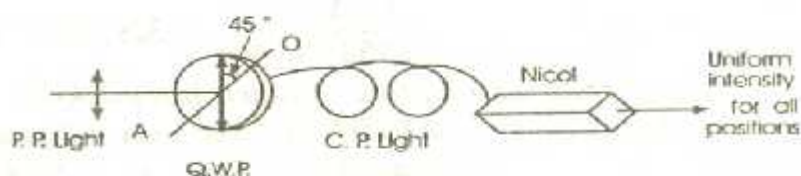

difference of $\lambda / 4$ between them.

- ❖ A parallel beam of mono-chromatic plane polarised light is allowed to fall normally on a Q. W.P. such that the vibrations in the incident plane polarised light make an angle of 45° , with the optic axis of the plate. The light emerging from the Q.W.P., is circularly polarised.

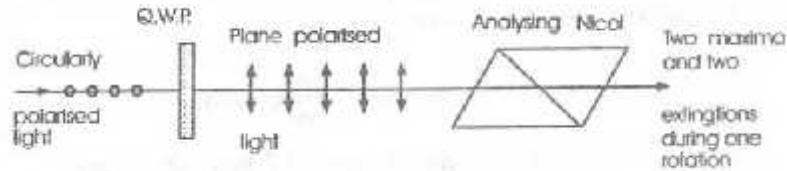

Detection:

- ❖ The circularly polarised light, when observed through a rotating Nicol, shows no variation in intensity. If ordinary unpolarized light is viewed by a rotating Nicol, the intensity here also remains constant. In this respect circularly polarised light resembles ordinary unpolarized light. We can distinguish between them by using a Q.W.P.
- ❖ If circularly polarised light is passed through a Q.W.P., it is converted into plane polarised light. This plane polarised light can be extinguished by means of a rotating Nicol twice in a rotation. On the other hand, ordinary unpolarised light on passing through a Q.W.P. remains ordinary unpolarised light. It cannot be extinguished by a rotating Nicol.

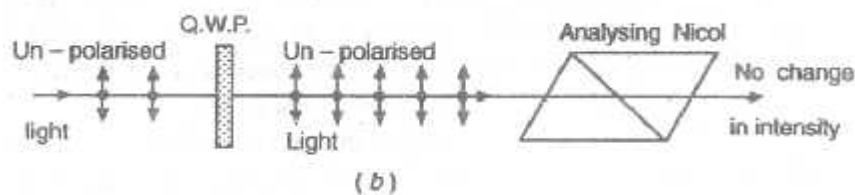

Production of elliptically polarised light:

- ❖ Monochromatic plane polarised light is allowed to fall normally on a Q.W.P, such that the vibrations in the plane, polarised incident light make an angle θ ($\theta \neq 0, 45^\circ, 90^\circ$) with the optic axis of the plate.

- ❖ The plane polarised light on entering the Q.W.P. is split up into O and E components having unequal amplitudes. On emergence from the Q.W.P. there is a phase difference of $\pi/2$ between the two components. They combine to form elliptically polarised light.

Detection:

- ❖ If elliptically polarised light is examined using a Nicol, the intensity of the emergent light varies between a maximum and a non-zero minimum as the Nicol is rotated.

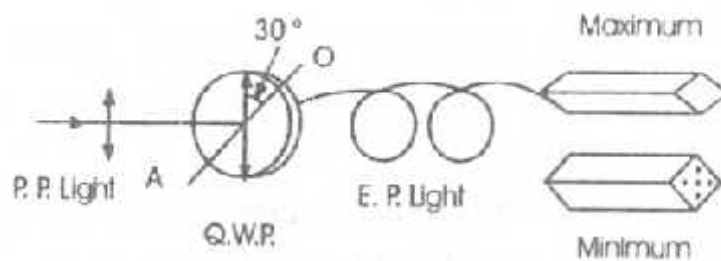

- ❖ The intensity will be maximum when the principal plane of the Nicol is parallel to the major axis of the ellipse. The intensity will be minimum when the principal plane is parallel to minor axis.
- ❖ Partially plane polarised light also behaves in the same manner when examined through a Nicol.
- ❖ To distinguish between elliptically polarised and partially plane polarised light, it is passed through a Q.W.P. The Q.W.P. converts the elliptically polarised light into plane polarised light. It will give two maximum and two complete extinctions when observed through a rotating Nicol.
- ❖ On the other hand, if the incident light is partially plane polarised light, it will remain as such when passed through the Q.W.P. If this is examined using a Nicol the intensity varies between a maximum and non-zero minimum as the Nicol is rotated.

Analysis of polarised light:

- ❖ Suppose we are supplied with light coming out from a hole and are asked to find its state of polarization. The light may be (i) unpolarised, (ii) plane polarised, (iii) partially plane polarised, (iv) circularly polarised or (v) elliptically polarised. A Nicol prism and a quarter wave plate are taken and the following tests are applied.

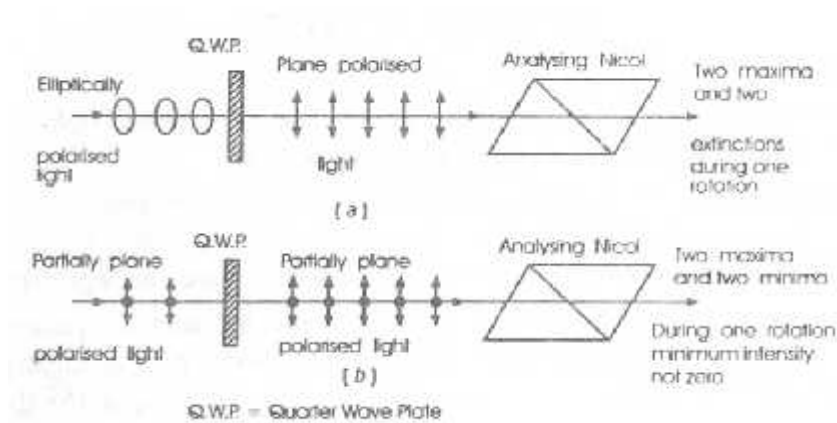

- ❖ The given beam of light is passed through a Nicol prism. The Nicol prism is rotated about the direction of propagation of light as axis. The changes in intensity are noted. There are three possibilities:
 - The intensity does not vary at all. Then the given beam of light is either unpolarised or circularly polarised.
 - The intensity shows variations—two maxima and two minima during one rotation but intensity is never zero. Then the given beam of light is either partially plane polarised or elliptically polarised.
 - The intensity shows variations and completely extinguished twice in each rotation. Then the given beam of light is completely plane polarised.
- ❖ To distinguish between circularly polarised light and unpolarised light the given beam of light is first passed through a Q. WP., and then examined through a rotating Nicol.
 - If the intensity varies with zero minimum, the given light is circularly polarised.
 - If there is no variation in intensity, the given beam of light is unpolarised.

- ❖ To distinguish between elliptically polarised and partially plane polarised light, the Nicol is first adjusted for maximum intensity. Then a Q.W.P., is inserted between the given light and Nicol so that light falls normally on it and its optic axis is parallel to the principal section of the Nicol.
- i. On rotating the Nicol, if the intensity varies with zero minimum, the given light is elliptically polarised.
- ii. On rotating the Nicol, if the emergent light shows variation in intensity with a non-zero minimum, the given beam of light is partially plane polarised.

Optical Activity:

- ❖ The property of rotating the plane vibration of polarised light by certain crystals and other substances is called optical activity.
- ❖ Substances which rotate the plane of polarization are known as optically active substances. Substances like cinnabar, sodium chlorate, sugar crystals, turpentine oil, sugar solution, quinine sulphate solution etc., are optically active.

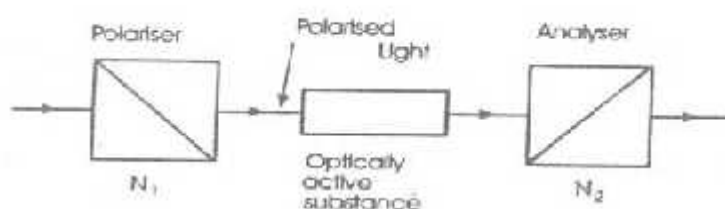

- ❖ If we take two crossed Nicols N_1 , and N_2 , the light incident on N_1 , does not pass through N_2 . But if we introduce some particular substance (such as sugar solution, quartz crystal etc.) between these crossed Nicols, N_1 and N_2 , then some light begins to pass through N_2 .
- ❖ The light is, however, again completely cut off if N_2 is rotated through a certain angle. This shows that the light emerging from the quartz crystal is still plane-polarised, but its plane of polarisation has been

rotated by the quartz crystal through a certain angle. Thus quartz is optically-active.

- ❖ There are two types of optically-active substances. Those which rotate the plane of polarization clockwise (looking against the direction of light) are called 'dextro-rotatory' or 'right-handed', while those which rotate anti-clockwise are called 'laevo-rotatory' or 'left-handed'. Quartz occurs in both forms. Cane sugar is dextro whereas fruit sugar is laevo. The angle through which the plane of polarization is rotated by the substance is called the angle of rotation θ .

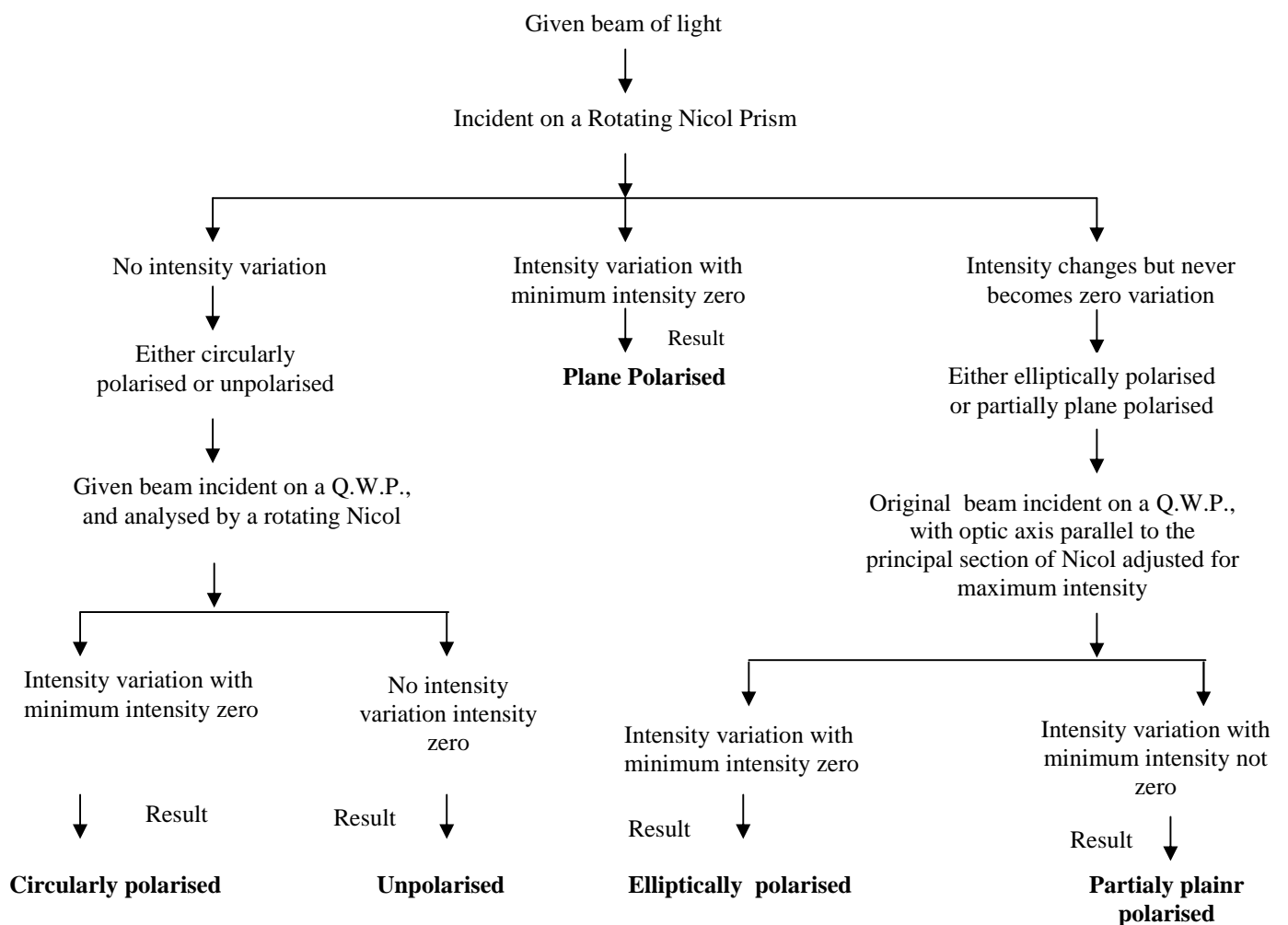

Laurent's Half- shade Polarimeter:

- ❖ Its optical parts are shown in. Light from a monochromatic source S is rendered parallel by a convex lens L and falls on the polarising Nicol P which converts it into plane polarised light. This light passes through a half-shade device H and then through the tube T containing the solution.
- ❖ The transmitted light passes through the analyser A. The light emerging from the analyser is observed through a telescope G. The analysing Nicol A can be rotated about the axis of the tube and its position can be read on a circular scale S.

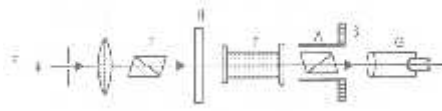

Working of the half-shade device:

- ❖ It consists of a semicircular glass plate XBY cemented to a semicircular quartz plate XDY. The quartz plate is cut with its optic axis parallel to the line of separation XCY. The thickness of the quartz plate is such that it introduces a phase difference of π between the O and E vibrations, i.e., it is a half wave plate. The thickness of the glass plate is such that it absorbs the same amount of light as the quartz plate.
- ❖ The light from the polariser (P) is plane polarised and falls normally on the half-shade plate.

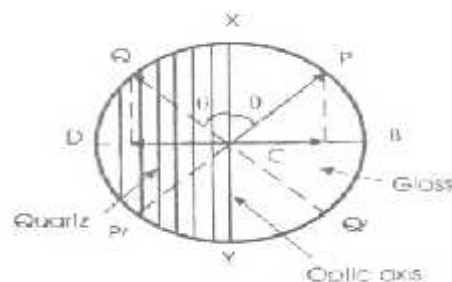

- ❖ Let CP be the direction of vibrations in the plane polarised light. CP is inclined at an angle θ to the optic axis XY of the quartz half. On passing through the glass half, the vibrations will remain along CP.

But on passing through the quartz half, the vibrations will be split up into E and O components.

- ❖ The vibrations of the O component are along CB and those of E component along CX.. O component travels faster than the E component within quartz. Hence, on emergence, the O component gains a phase of π over the E component.
- ❖ Thus, on emergence from the quartz plate, O component has vibrations along CD . The E component has vibrations still along CX. Thus the light emerging from the quartz plate has resultant vibration along CQ such that $\angle PCX = \angle QCX = \theta$. Thus the effect of quartz plate is to rotate the plane of polarization by an angle 2θ .
- ❖ Thus there are two plane polarised beams. One emerges from the glass plate with vibrations in the plane CP, while the other emerges from the quartz plate with vibrations in the plane CQ.
- ❖ Let the principal plane of the analysing Nicol be parallel to QCQ'. Then light from the quartz plate will pass through the analyser. But the light from the glass plate will be partly stopped by the analyser. Hence quartz half will be brighter than the glass half.

UNIT – IV

ABERRATION

MONOCHROMATIC ABERRATION:

- ❖ The deviations in the size, shape, position and color in the actual images produced by a lens in comparison to the object are called aberrations. Chromatic aberrations are distortions of the image due to the dispersion of light in the lenses of an optical system when light is used.
- ❖ The defect of colored image formed by a lens with white light is called chromatic aberration. If monochromatic light is used, then such defects are automatically removed. Besides these defects, there are defects which are present even when monochromatic light is used. Such defects are called monochromatic aberrations. These aberrations are result of
 - ❖ The large aperture of the optical system.
 - ❖ The large angle subtended by the rays with the principal axis and,
 - ❖ The large size of the object.

As a result of these aberrations,

1. a point is not imaged as a point
2. a plane is not imaged as a plane and
3. equidistant points are not imaged as equidistant points.

Following are the monochromatic aberrations:

- i. Spherical aberration
- ii. Astigmatism
- iii. Coma
- iv. Curvature of field and
- v. Distortion.

Spherical aberration:

- ❖ This aberration is due to large aperture of the lenses. the lens of large aperture may be thought to be made up of zones. The marginal and paraxial rays form images at different places. Fig. shows that a monochromatic point source S on the axis is imaged as S_p and S_m

Here S_m and S_p are the images formed by marginal and paraxial rays respectively.

- ❖ Thus the point object is not imaged as a point. Similarly, the focus of marginal and paraxial rays do not coincide. The distance $S_m S_p$ on the axis measures longitudinal spherical aberration.

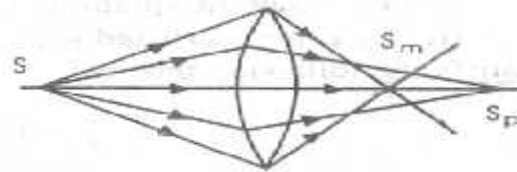

- ❖ The failure of a lens from a point image of a point on the axis is called spherical aberration.

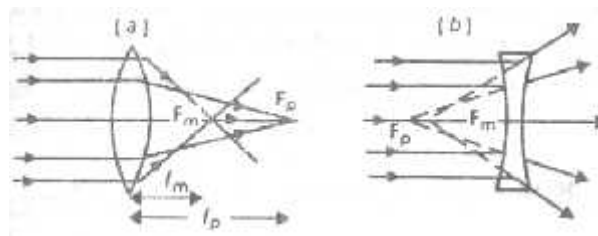

- ❖ For rays parallel to principal axis, the distance between the foci of marginal and paraxial rays gives the extent of longitudinal spherical aberration. In fig. F_p and F_m are the foci for the paraxial and the marginal rays respectively.
- ❖ Spherical aberration of a convergent lens is taken to be positive as the distance $(f_p - f_m)$ measured along the axis. The spherical aberration of a diverging lens is negative.

Methods of minimizing spherical aberration:

The following methods are used to reduce spherical aberration.

By using stops:

- ❖ By using stops, we can reduce the lens aperture. We can use either paraxial or marginal rays. Here, circular discs, called the stops, are used to cut off the unwanted rays. The stop is a disc with a circular hole. It eliminates marginal rays. A stop to eliminate paraxial rays. But the use of stops reduces the intensity of the image and the resolving power of the instrument.

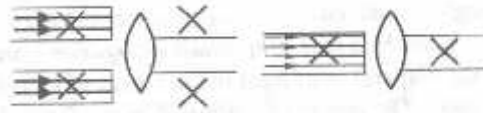

By using the two lenses separated by a distance:

- ❖ When two convex lenses separated by a finite distance are used the spherical aberration is minimum when the distance between the lenses is equal to the difference in their focal lengths. In this arrangement, the total deviation is equally shared by the two lenses. hence the spherical aberration is minimum.

By using a crossed lens:

- ❖ The radii of curvature R_1 , R_2 of a thin lens satisfy the following relation:

$$\frac{1}{f} = (n-1) \left(\frac{1}{R_1} - \frac{1}{R_2} \right)$$

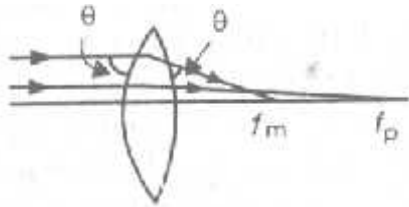

- ❖ It, therefore shows that spherical aberration depends upon (i) the refractive index of the lens medium (n) and (ii) the shape factor s which is determined by the ratio $s = R_1/R_2$. If the refractive index of material of the lens is 1.5, the spherical aberration will be minimum when $s = R_1/R_2 = -1/6$. A convex lens whose radii of curvatures bear the said ratio is called as a crossed lens.
- ❖ It is essential to divide the deviation on two surfaces equally. The axial and marginal rays of light come to focus with minimum of spherical aberration.

Coma:

- ❖ When a lens corrected for spherical aberration, it forms a point image of a point object situated on the axis. But if the point object is situated off the principal axis, the lens, even corrected for spherical aberration, forms a comet-like image in place of point image. This defect in the image is called Coma.

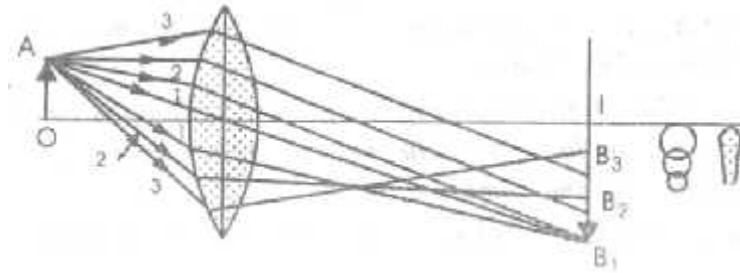

- ❖ Consider an off axis point A in the object. The rays leaving A and passing through the different zones of the lens such as 1, 2, 3 are brought to focus at different points B₁, B₂, B₃ gradually nearer to the lens. The radius of these circles go on increase in radius of zone. Thus the resultant image is comet like.

Removal of coma:

The comatic aberration may be eliminated as follows:

1. By using a stop before the lens and so making the outer zones ineffective.
2. By properly choosing the radii of curvature of the lens surfaces. For example, for an object situate at infinity, the comatic aberration may be minimized by taking a lens of $n=1.5$ and

$$k = \frac{R_1}{R_2} = -\frac{1}{9}$$

3. **Abbe sine condition.** Abbe showed that coma may be eliminated if each zone of the lens satisfies the Abbe sine condition.

$$n_1 h_1 \sin \theta_1 = n_2 h_2 \sin \theta_2$$

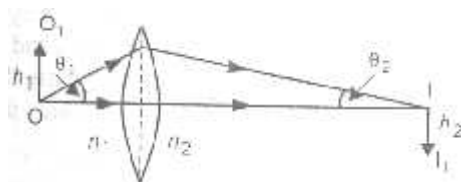

- ❖ Here n_1 and n_2 are refractive indices of the object and image regions respectively. h_1 and h_2 are the heights of the object and the image. θ_1 and θ_2 are the angles which the incident and the conjugate emergent rays make with the axis.

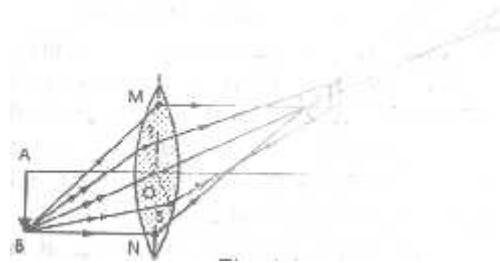

if this condition is satisfied, the lateral magnification

$$\frac{h_2}{h_1} = \frac{n_1 \sin \theta_1}{n_2 \sin \theta_2}$$

will be same for all the rays of light, irrespective of the angles θ_1 and θ_2 . Therefore coma will be eliminated.

Curvature of Fields:

- ❖ Even if a lens is free from spherical aberration, coma and astigmatism, the image of an extended plane object OO' is curved. If a screen is placed at I perpendicular to the axis, the complete image I' will not be in focus.

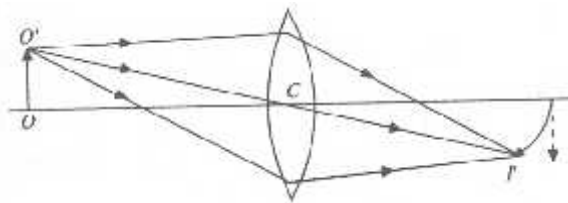

- ❖ This defect is called 'curvature'. It arises because the points away from the axis, such as O' , are at a greater distance from the center C' of the lens than the axial point O . Hence the image I' is formed at a smaller distance than I .

Removal of Curvature

i). In case of a single lens, curvature can be minimized by using suitable stops.

ii). For a combination of lenses, the condition for absence of curvature is

$$\sum \frac{1}{nf} = 0$$

Hence n is the refractive index and f is the focal length of a lens. For two lenses (whether in contact or separated by a distance) the condition reduces to

$$\frac{1}{n_1 f_1} + \frac{1}{n_2 f_2} = 0$$
$$n_1 f_1 + n_2 f_2 = 0$$

This is known as Petzval's condition.

Since n_1, n_2 are positive, f_1 and f_2 must have opposite signs. Hence by combining a convex lens of a certain material with a concave lens of the suitable material and focal length, a flat field is obtained.

Distortion:

- ❖ When a stop is used with a lens to reduce the various aberrations, the image of a plane square-like object placed perpendicular to the axis is not of the same shape as the object. This defect is called 'distortion'.
- ❖ This is because the chief rays forming images of different points on the object pass through different portions of the lens. Hence different parts of the object suffer different magnifications.

There are two types of distortions (i) barrel-shaped, (ii) pin-cushion shaped.

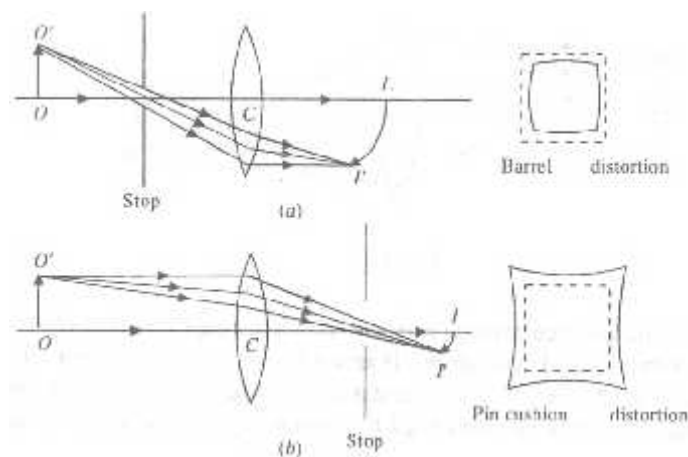

- ❖ When the stop is placed on the object side of the lens the magnification of the outermost part of the plane object is less than that of the central part producing barrel-shaped distortion. If the stop is placed on the image side of the lens, then the outermost parts of the object are magnified more than the central parts, producing pin-cushion-shaped distortion.

Removal of Distortion:

- ❖ A combination of two similar meniscus convex lenses, with their concave surfaces facing each other and having an aperture stop in the middle is free from distortion, when the object and image are symmetrically placed. In this manner the pin-cushion-shaped distortion due to the first lens is exactly nullified by the barrel-shaped distortion due to the second lens.

Chromatic Aberration

The focal length of a lens is given by

$$\frac{1}{f} = (n-1) \left(\frac{1}{R_1} - \frac{1}{R_2} \right)$$

- ❖ Since n changes with the colour of light, f must be different for different colours. This change of focal length with colour is responsible for chromatic aberration. It is classified into two types: a) Longitudinal chromatic aberration, b) Lateral chromatic aberration.

Longitudinal chromatic aberration:

- ❖ A beam of white light is incident on a convex lens parallel to the principal axis. The dispersion of colours takes place due to prismatic action of the lens. Violet is deviated most and red the least. Red rays are brought to focus at a point farther than the violet rays. Evidently $f_r > f_v$. The difference $f_r - f_v$ is a measure of the axial chromatic aberration of a lens for parallel rays.

Expression for Longitudinal chromatic aberration:

The focal length of a lens is given by

$$\frac{1}{f} = (n-1) \left(\frac{1}{R_1} - \frac{1}{R_2} \right)$$

Let f_v , f_r and f_y be the focal lengths of the lens for violet, red and yellow colours respectively. Also let n_v , n_r and n_y be the respective refractive indices. Then,

$$\frac{1}{f_v} = (n_v - 1) \left(\frac{1}{R_1} - \frac{1}{R_2} \right) \quad \text{--- (1)}$$

$$\frac{1}{f_r} = (n_r - 1) \left(\frac{1}{R_1} - \frac{1}{R_2} \right) \quad \text{--- (2)}$$

$$\frac{1}{f_y} = (n_y - 1) \left(\frac{1}{R_1} - \frac{1}{R_2} \right) \quad \text{--- (3)}$$

Subtracting Eq. (2) from Eq. (1)

$$\frac{1}{f_v} - \frac{1}{f_r} = (n_v - n_r) \left(\frac{1}{R_1} - \frac{1}{R_2} \right)$$

or

$$\frac{f_r - f_v}{f_v f_r} = \frac{n_v - n_r}{n_y - 1} (n_y - 1) \left(\frac{1}{R_1} - \frac{1}{R_2} \right)$$

Now $\check{S} = (n_v - n_r)/(n_y - 1) =$ dispersive power of the material of the lens, $f_v f_r = f_y^2$

$$\therefore \quad f_r - f_v = \check{S} f_y$$

Lateral chromatic aberration:

- ❖ A convex lens and an object AB placed in front of the lens. The lens forms the images of white object AB as B_vA_v and B_rA_r in violet and red colours respectively. The images of other colours lie in between the two. Evidently, the size of red image is greater than the size of violet image ($B_rA_r > B_vA_v$). The difference ($B_rA_r - B_vA_v$) is a measure of lateral or transverse chromatic aberration.

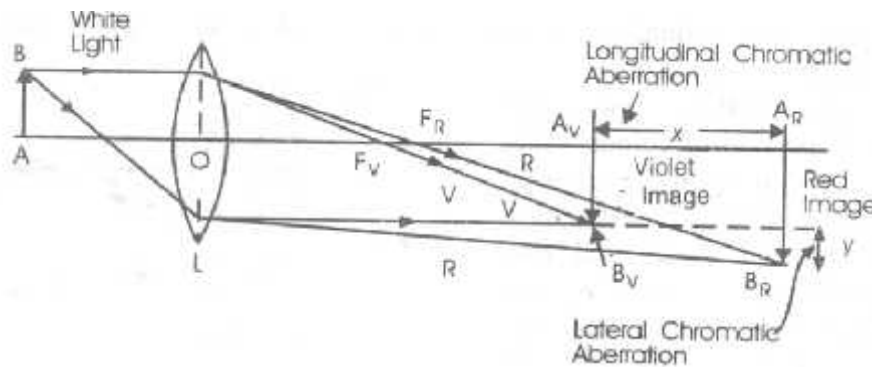

Chromatic aberration is eliminated by.

- keeping two lenses in contact with each other and
- keeping two lenses out of contact.

The chromatic doublet:

- ❖ When two or more lenses are combined together in such a way that the combination is free from chromatic aberration, then such a combination is called an achromatic combination of lenses.
- ❖ The minimization or removal of chromatic aberration is called achromatization. Chromatic aberration cannot be removed completely. Usually achromatism is achieved for two prominent colours.

Equivalent focal length of two thin lenses separated by a distance:

- ❖ Let L_1 and L_2 be two thin lenses of focal lengths f_1 and f_2 placed in air coaxially a distance a apart. Consider a ray PA incident on L_1 parallel to the axis at a height h_1 above the axis. This ray after refraction through the first lens is directed towards D which is the second principal focus of L_1 .

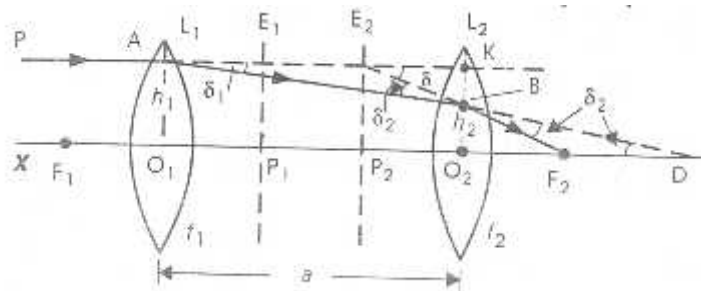

Then deviation produced by first lens = $\delta_1 = h_1/f_1$.

- ❖ The emergent ray from the first lens strikes the lens L_2 at a height h_2 . The lens L_2 deviates it further through an angle δ_2 . Finally the ray meets the axis at F_2 . F_2 is the second principal focus of the lens system.

Deviation produced by the second lens = $\delta_2 = h_2/f_2$.

- ❖ PA and F_2B are produced to cut at E_2 . Then a single convex lens placed in the position E_2P_2 and having focal length P_2F_2 is equivalent to the lens system. Thus, $P_2F_2 = f$ is the equivalent focal length. Then, deviation produced by equivalent lens = $\delta = h_1/f$. now, $d = d_1 + d_2$

$$\therefore \frac{h_1}{f} = \frac{h_1}{f_1} + \frac{h_2}{f_2} \quad \text{---- (1)}$$

$$\text{Now, } h_2 = O_2B = O_2K - BK = h_1 - a\delta_1 = h_1 - \frac{ah_1}{f_1} = h_1 \left(1 - \frac{a}{f_1} \right)$$

$$\text{substituting the value of } h_2 \text{ in eq. (1), } \frac{h_1}{f} = \frac{h_1}{f_1} + \frac{h_1}{f_2} \left(1 - \frac{a}{f_1} \right)$$

$$\text{or } \frac{1}{f} = \frac{1}{f_1} + \frac{1}{f_2} - \frac{a}{f_1 f_2} \quad \text{--- (2)}$$

$$\therefore f = \frac{f_1 f_2}{f_1 + f_2 - a} = -\frac{f_1 f_2}{\Delta} \quad \text{---(3)}$$

Here, $\Delta = a - (f_1 + f_2)$ is known as the optical separation or optical interval between the two lenses.

Let us find the position of the equivalent lens, i.e., the distance O_2P_2 .

The triangles BF_2O_2 and $E_2F_2P_2$ are similar.

$$\therefore \frac{h_2}{h_1} = \frac{O_2F_2}{P_2F_2} \quad \text{or} \quad O_2P_2 = \frac{h_2}{h_1} P_2F_2 = \left(1 - \frac{a}{f_1}\right) f \left(\because \frac{h_2}{h_1} = 1 - \frac{a}{f_1}\right)$$

$$\begin{aligned} \text{Now, } O_2P_2 &= P_2F_2 - O_2F_2 = f - f \left(1 - \frac{a}{f_1}\right) = \frac{fa}{f_1} \\ &= \left(\frac{f_1 f_2}{f_1 + f_2 - a}\right) \frac{a}{f_1} = \frac{af_2}{f_1 + f_2 - a} \end{aligned}$$

Let $O_2P_2 = -s$ ($\because P_2$ lies to the left of the lens L_2).

$$s = \frac{-af_2}{f_1 + f_2 - a} = \frac{-fa}{f_1} \quad \text{--- (4)}$$

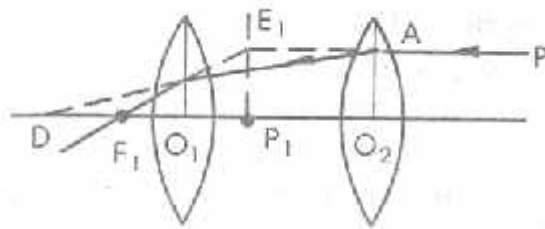

- ❖ Similarly, consider a ray parallel to the axis incident from the right hand side. Then we can find the position of F_1 , the point where the ray intersects the principal axis after refraction through the lens system. E_1P_1 is the first principal plane. P_1 is the first principal point of the lens system. The distance of the first principal point from the first lens is

$$r = O_1P_1 \cdot O_1P_1 = r = \frac{-af_2}{f_1 + f_2 - a} = \frac{af}{f_2} \quad \text{--- (5)}$$

The first principal focus F_1 is situated at a distance f towards the left of the point P_1 .

If P_1 and P_2 are the powers of the component lenses and P the power of the combination, then by Eq. (2), $P = P_1 + P_2 - aP_1P_2$.

Huygens's eyepieces:

- ❖ It consists of two planoconvex lenses of focal lengths $3f$ (field lens) and f (eye lens) placed a distance $2f$ apart. They are arranged with their convex faces towards the incident rays. The eye-piece satisfies the following conditions of minimum spherical and chromatic aberrations.

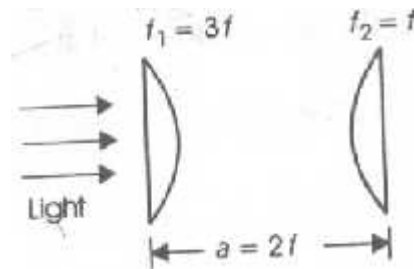

- The distance between the two lenses for minimum spherical aberration is given by $a = f_1 - f_2$. In Huygen's eyepiece, $a = 3f - f = 2f$. Hence this eyepiece satisfies the condition of minimum spherical aberration.
- For chromatic aberration to be minimum $a = (f_1 + f_2)/2$. In Huygen's eyepiece, $a = (3f + f)/2 = 2f$. Hence this eyepiece satisfies the condition of minimum chromatic aberration.

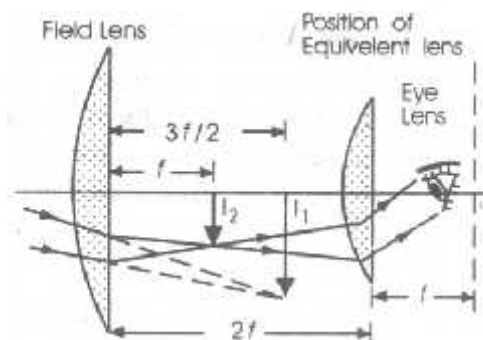

Working: An eyepiece forms the final image at infinity. Thus the field lens forms the image I_2 , in the first focal plane of eye-lens. i.e., at a distance f to the left of eye-lens. now the distance between the field lens and eye-lens is $2f$. Therefore the image I_2 lies at a distance f to the right of field lens. The image I_1 formed by the objective of microscope or telescope acts as the virtual object for the field lens. Thus we treat I_1 as the virtual object for the field lens, and I_2 as the image of I_1 , due to it or $v=f$, $F=3f$, $u=?$ we have

$$\frac{1}{v} - \frac{1}{u} = \frac{1}{F} \text{ or } \frac{1}{f} - \frac{1}{u} = \frac{1}{3f}$$

$$\therefore u = 3f/2$$

ie. I_1 should be formed at a distance $(3/2)f$ from the field lens. therefore the rays coming from the objective which coverage towards I_1 , are focused by the field lens at I_2 . the rays starting from I_2 emerge from the eye-lens as a parallel beam.

Cardinal Points of Huygens Eyepiece:

The equivalent focal length F of this eyepiece is

$$\frac{1}{F} = \frac{1}{f_1} + \frac{1}{f_2} - \frac{a}{f_1 f_2} = \frac{1}{3f} + \frac{1}{f} - \frac{2f}{3fx} = \frac{2}{3f}$$

$$\therefore F = 3f/2$$

The second principal point is at a distance β from the eye lens.

$$\beta = -\frac{f_2 a}{f_1 + f_2 - a} = \frac{-fx2f}{3f + f - 2f} = \frac{-2f^2}{2f} = -f$$

The first principal point is a distance α from the field lens.

$$\alpha = +\frac{f_1 a}{f_1 + f_2 - a} = \frac{3fx2f}{3f + f - 2f} = \frac{6f^2}{2f} = 3f$$

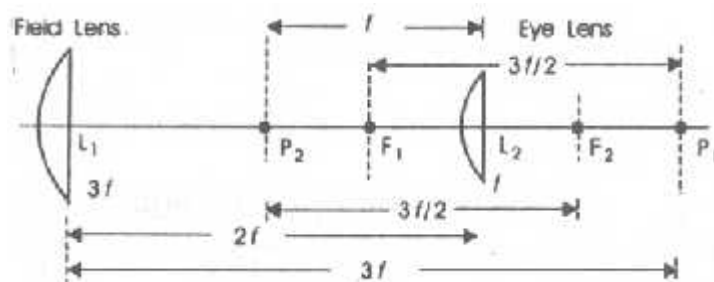

- ❖ The position of the principal point P_1 and P_2 and the principal foci F_1 and F_2 are shown. Since the system is in air, the nodal points coincide with the principal points.

Ramsden's Eyepiece:

- ❖ It consists of two plano convex lenses each of focal length f . The distance between them is $(2/3)f$. For achromatism, the distance between the two lenses should be $a = (f_1 + f_2)/2 = \frac{(f + f)}{2} = f$ But here $a = (2/3)f$.

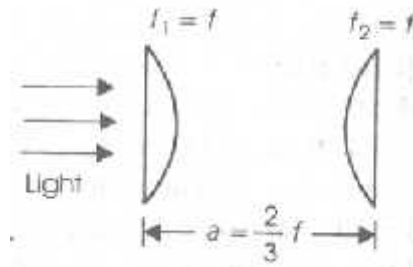

- ❖ Thus in this eyepiece the chromatic aberration is only partly reduced. Similarly, for minimum spherical aberration, $a = f_1 - f_2 = f - f = 0$. hence the spherical aberration is not at all reduced. This is a demerit of this eyepiece.

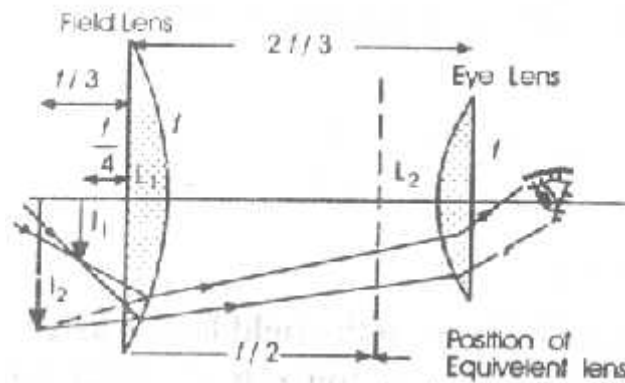

Working:

- ❖ I_1 is the image formed by the objective of the microscope or telescope. It serves as an object for eyepiece. The eyepiece is adjusted such that the image I_2 , formed by the field lens lies in the first focal plane of the eye lens.
- ❖ Then the eye piece forms the final image at infinity. Since the focal length of the eye lens is f and $a = (2/3)f$, I_2 is at a distance $f/3$ from the

field lens. Now, the image I_1 due to objective serves as the object for field lens. I_2 is the image of I_1 due to field lens. or $v=-f/3$, $F=f$, $u=?$

$$\frac{1}{v} - \frac{1}{u} = \frac{1}{F} \text{ or } \frac{1}{-f/3} - \frac{1}{u} = \frac{1}{f} \text{ or } \frac{1}{u} = -\frac{4}{f}$$

$$u = -f/4$$

- ❖ Thus the eyepiece is so adjusted that the image (I_1) formed by the objective of telescope or microscope lies at a distance $f/4$ towards the left of field lens. The crosswire is placed at I_1 . I_1 serves as the object for field lens and its image is formed at I_2 .

Cardinal points:

The focal length F of the equivalent lens is

$$\frac{1}{F} = \frac{1}{f_1} + \frac{1}{f_2} - \frac{a}{f_1 f_2} = \frac{1}{f} + \frac{1}{f} - \frac{2f/3}{f^2} = \frac{4}{3f} \therefore F = 3f/4$$

$$\beta = \frac{f_2 a}{f_1 + f_2 - a} = \frac{-fx(2f/3)}{2f - (2f/3)} = \frac{-f}{2}$$

$$\alpha = \frac{f_1 a}{f_1 + f_2 - a} = \frac{fx(2f/3)}{2f - (2f/3)} = +\frac{f}{2}$$

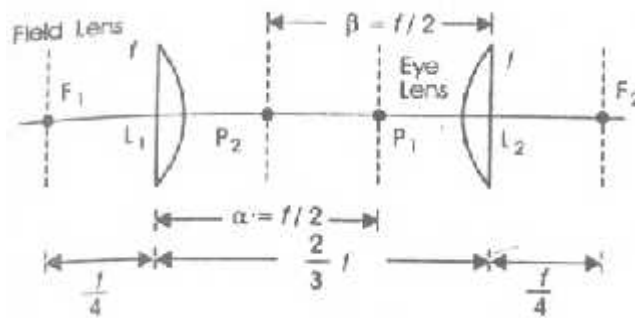

- ❖ The position of the principal point P_1 and P_2 and the principal foci F_1 and F_2 are shown. Since the system is in air, the nodal points coincide with the principal points.

Distance of the first principal focus from the field lens of the eyepiece

$$= F_1 L_1 = F_1 P_1 - \alpha = 3f/4 - f/2 = f/4.$$

Similarly the distance of the second principal focus from the eye lens is

$$L_2F_2 = P_2F_2 - \beta = 3f/4 - f/2 = f/4.$$

Importance and determination of velocity of light:

The velocity of light in vacuum (c) is a constant of nature. Its significance in physics will be clear from the following:

- a. The ratio of the velocity of light in vacuum to that in a medium represents the refractive index of the medium. Hence, from a knowledge of the velocity of light in a medium, its refractive index can be obtained.
- b. According to Einstein, the velocity of light is a universal constant. It is, therefore, adopted as a standard of measurement in Geodetic surveys. In spectroscopy, the wavelengths of spectral lines are determined experimentally. The corresponding frequencies (ν) can be calculated from the formula $\nu = c/\lambda$, if c is accurately known.
- c. It enables the energy and momentum of a given quantity of radiation to be determined. $E = mc^2$. Also $E = h\nu$. Hence $h\nu = mc^2$ or $m = h\nu/c^2$.
Momentum = mass x velocity = $(h\nu/c^2)c = h\nu/c$.

Piezoelectric grating method:

Principal:

- ❖ In this method *piezo- electric effect* is used for the alternate interruptions of a beam of light. According to this effect, if a quartz crystal is suitable cut and subjected to a high frequency alternating electric field, it is alternately compressed and extended. Thus high frequency oscillations are generated.
- ❖ When these high frequency oscillations are set up in the form of pulses in a quartz crystal, it is crossed by several parallel nodal planes. The intensity and refractive index at nodal planes is different from those at other planes. Thus the crystal acts as a diffraction grating.

Experiment:

- ❖ Houston's arrangement for determining velocity of light. Monochromatic light from a source S after reflection from the glass plate M emerges through a convex lens L as a parallel beam.
- ❖ Then the light is allowed to fall on the quartz crystal C. The quartz crystal acts as a diffraction grating with a frequency double the frequency of oscillations. Then the light passes through the slit A of the screen XY. Finally the light is focused by the lens L1.
- ❖ The convex lens L1 and the refracting concave mirror B are fixed at the two ends of a tube T. The distance between them is the focal length of L1. Further this distance is also equal to the radius of curvature of the concave mirror B.

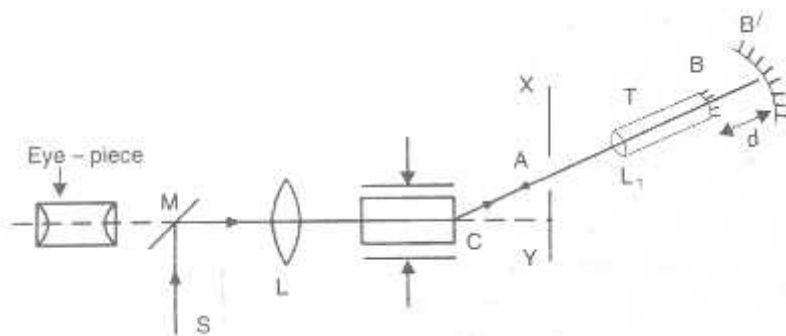

- ❖ This light completely retraces its path from B. Suppose the returning beam of light finds the vibrating crystal in the same condition as it was when the light went out from it. Then the light emerges in the direction CM. Therefore, the eye sees an image of S. If there is any change in the condition of the crystal, then no image will be formed at the eyepiece.
- ❖ Let f be the frequency of oscillations of the crystal. Then the rate of formation of the grating is $2f$ per second. Therefore, when the image is

seen by the eye, the time taken by light to go from C to B and back is a simple multiple of $(1/2f)$.

- ❖ The tube T is moved away from the screen along CB. Initially, the image disappears. The image will reappear when the tube reaches some position B'. This will be so, when the distance BB' and back (i.e. $2d$) is traveled by light in the time $(1/2f)$ second. By taking several such positions, the mean value of d is determined.

Velocity of light $c = \text{distance traveled} / \text{time taken} =$

$$\frac{2d}{1/(2f)} = 4df$$

The value of the velocity of light in vacuum calculated by Houston was $299,782 \pm 9 \text{ km/s}$. This value agrees very closely with values obtained from other accurate experiments.

Kerr cell Method:

- ❖ It consists of a Kerr cell K placed between two crossed nicol prisms N_1 and N_2 . Kerr cell is small glass container having two electrodes filled with nitrobenzene. When a high voltage is applied to the electrodes of K, the light is transmitted through the system. On the other hand, when the field is switched off, the light is stopped and not transmitted through the system.
- ❖ Thus, by using an electrical oscillator which supplies high frequency voltage, the beam of light can be interrupted at the rate of many million of times in one second.

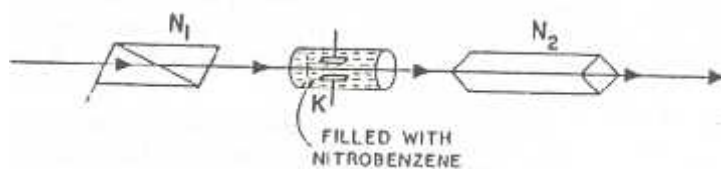

- ❖ Light from a source S after passing through the lens L_1 is made to pass through the nicol prism N_1 and it becomes plane polarized.

- ❖ This beam of light is focused at the center of the Kerr cell K_1 and falls on the nicol prism N_2 . this beam of light is rendered parallel by the lens L_2 and after reflection from the plane mirror is allowed to fall on the lens L_3 which concentrates the beam in the middle of the Kerr cell K_2 . Finally the beam passes through the nicol prism N_3 and the lens L_4 .
- ❖ As the two nicol prism N_1 and N_2 are crossed, no light reaches the mirror M and the eye. When a high frequency voltage is applied to the Kerr cell K_1 the beam reaches the mirror M and is reflected. As this reflected beam N_3 and no light is observed by the eye. It should be remembered that N_2 and N_3 are crossed.
- ❖ Suppose, a high voltage frequency oscillatory voltage is applied to the Kerr cells K_1 and K_2 simultaneously such that there is no phase difference in their voltages. This means that the two cells will act as two shutters and are allowed to open and close simultaneously. Further consider the light passing through the cell K_1 when the voltage is maximum and reaching the cell K_2 , after some time when the voltage across the cell K_2 is minimum. Then no light reaches the eye.

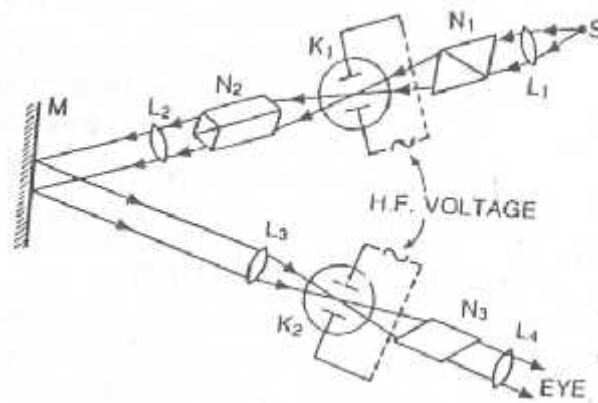

- ❖ Thus, we find similar to Fizeau's method, the arrangement N_1 , K_1 and N_2 acts as a space for the passage of light while the arrangement of K_2 and N_3 acts as a toothed wheel for the obstruction of light.

- ❖ If the distance between the two cells is d and f is the frequency of the H.F. voltage, then time taken by light to travel from K_1 to K_2 .

$$t = \frac{1}{4f} \quad \text{but} \quad c = \frac{d}{t}$$

$$c = \frac{d}{\frac{1}{4f}} = 4fd$$

In this method,

$$f = 3 \times 10^6 \text{ hertz.}$$

and the value of c was found to be $2.99778 \times 10^8 \pm 20 \times 10^3 \text{ m/s}$.

Advantages:

1. As the frequency is very high, this device is capable of chopping a beam light several hundred times more rapidly than can be done by the toothed wheel. hence a shorter base line can be used.
2. The apparatus can be set up in a laboratory.
3. The accurate frequency of the high frequency oscillator is known.

UNIT V

FIBER OPTICS

fibre optic system

1. Broad Bandwidth

Broadband communication is very much possible over fiber optics which means that audio signal, video signal, microwave signal, text and data from computers can be modulated over light carrier wave and demodulated by optical receiver at the other end. It is possible to transmit around 3,000,000 full-duplex voice or 90,000 TV channels over one optical fiber.

2. Immunity to Electromagnetic Interference

Optical fiber cables carry the information over light waves which travel in the fibers due to the properties of the fiber materials, similar to the light traveling in free space. The light waves (one form of electromagnetic radiation) are unaffected by other electromagnetic radiation nearby. The optical fiber is electrically non-conductive, so it does not act as an antenna to pick up electromagnetic signals which may be present nearby. So the information traveling inside the optical fiber cables is immune to electromagnetic interference e.g. radio transmitters, power cables adjacent to the fiber cables, or even electromagnetic pulses generated by nuclear devices.

3. Low attenuation loss over long distances

There are various optical windows in the optical fiber cable at which the attenuation loss is found to be comparatively low and so transmitter and receiver devices are developed and used in these low attenuation region. Due to low attenuation of 0.2dB/km in optical fiber cables, it is possible to achieve long distance communication efficiently over information capacity rate of 1 Tbit/s.

4 Electrical Insulator

Optical fibers are made and drawn from silica glass which is nonconductor of electricity and so there are no ground loops and leakage of any type of current. Optical fibers are thus laid down along with high voltage cables on the electricity poles due to its electrical insulator behavior.

5 Lack of costly metal conductor

The use of optical fibers do not require the huge amounts of copper conductor used in conventional cable systems. In recent times, this copper has become a target for widespread metal theft due its inherent value on the scrap market

Fiber-optic communication compared to metallic cable:

Fiber-optic communication is a method of transmitting information from one place to another by sending pulses of light through an optical fiber. The light forms an electromagnetic carrier wave that is modulated to carry information. First developed in the 1970s, fiber-optic communication systems have revolutionized the telecommunications industry and have played a major role in the advent of the Information Age. Because of its advantages over electrical transmission, optical fibers have largely replaced copper wire communications in core networks in the developed world.

The process of communicating using fiber-optics involves the following basic steps: Creating the optical signal involving the use of a transmitter, relaying the signal along the fiber, ensuring that the signal does not become too distorted or weak, receiving the optical signal, and converting it into an electrical signal.

Communication :

Telecommunication is communication at a distance by technological means, particularly through electrical signals or electromagnetic waves. Due to the many different technologies involved, the word is often used in a plural form, as **telecommunications**.

Early telecommunication technologies included visual signals, such as beacons, smoke signals, semaphore telegraphs, signal flags, and optical heliographs.^[7] Other examples of pre-modern telecommunications include audio messages such as coded drumbeats, lung-blown horns, and loud whistles. Electrical and electromagnetic telecommunication technologies include telegraph, telephone, and teleprinter, networks, radio, microwave transmission, fiber optics, communications satellites and the Internet.

A revolution in wireless telecommunications began in the 1900s with pioneering developments in radio communications by Nikola Tesla and Guglielmo Marconi. Marconi won the Nobel Prize in Physics in 1909 for his efforts. Other highly notable pioneering inventors and developers in the field of electrical and electronic telecommunications include Charles Wheatstone and Samuel Morse (telegraph), Alexander Graham Bell (telephone), Edwin Armstrong, and Lee de Forest (radio), as well as John Logie Baird and Philo Farnsworth (television).

Basic principle:

The world's effective capacity to exchange information through two-way telecommunication networks grew from 281 petabytes of (optimally compressed) information in 1986, to 471 petabytes in 1993, to 2.2 (optimally compressed) exabytes in 2000, and to 65 (optimally compressed) exabytes in 2007. This is the informational equivalent of two newspaper pages per person per day in 1986, and six entire newspapers per person per day by

2007.^[9] Given this growth, telecommunications play an increasingly important role in the world economy and the global telecommunications industry was about a \$4.7 trillion sector in 2012. The service revenue of the global telecommunications industry was estimated to be \$1.5 trillion in 2010, corresponding to 2.4% of the world's gross domestic product.

Most utility poles are made of wood, pressure-treated with some type of preservative for protection against rot, fungi and insects. Southern yellow pine is the most widely used species in the United States; however, many species of long straight trees are used to make utility poles, including Douglas-fir, Jack pine, lodgepole pine, western red cedar, and Pacific silver fir.

Traditionally, the preservative used was creosote, but due to environmental concerns, alternatives such as pentachlorophenol, copper naphthenate and borates are becoming widespread in the United States. For over 100 years, the American Wood Protection Association (AWPA) has developed the standards for preserving wood utility poles. Despite the preservatives, wood poles decay and have a life of approximately 25 to 50 years depending on climate and soil conditions, therefore requiring regular inspection and remedial preservative treatments.

Other common utility pole materials are steel and concrete, with composites (such as fibreglass) also becoming more prevalent. One particular patented utility pole variant used in Australia is the Stobie pole, made up of two vertical steel posts with a slab of concrete between them.

In southern Switzerland along various lakes, telephone poles are made of granite. Starting in the early 1900s, these 18-foot (5 m) poles were originally used for telegraph wires and later for telephone wires. Because they are made of granite, the poles last indefinitely.

In practical fibers, the cladding is usually coated with a tough resin *buffer* layer, which may be further surrounded by a *jacket* layer, usually glass. These layers add strength to the fiber but do not contribute to its optical wave guide properties. Rigid fiber assemblies sometimes put light-absorbing ("dark") glass between the fibers, to prevent light that leaks out of one fiber from entering another. This reduces cross-talk between the fibers, or reduces flare in fiber bundle imaging applications.

Modern cables come in a wide variety of sheathings and armor, designed for applications such as direct burial in trenches, high voltage isolation, dual use as power lines, installation in conduit, lashing to aerial telephone poles, submarine installation, and insertion in paved streets. The cost of small fiber-count pole-mounted cables has greatly decreased due to the high demand for fiber to the home (FTTH) installations in Japan and South Korea.

Fiber cable can be very flexible, but traditional fiber's loss increases greatly if the fiber is bent with a radius smaller than around 30 mm. This creates a problem when the cable is bent around corners or wound around a spool, making FTTX installations more complicated. "Bendable fibers", targeted towards easier installation in home environments, have been standardized as ITU-T G.657. This type of fiber can be bent with a radius as low as 7.5 mm without adverse impact. Even more bendable fibers have been developed.^[56] Bendable fiber may also be resistant to fiber hacking, in which the signal in a fiber is surreptitiously monitored by bending the fiber and detecting the leakage.

Another important feature of cable is cable's ability to withstand horizontally applied force. It is technically called max tensile strength defining how much force can be applied to the cable during the installation period.

Some fiber optic cable versions are reinforced with aramid yarns or glass yarns as intermediary strength member. In commercial terms, usage of the glass yarns are more cost effective while no loss in mechanical durability of the cable. Glass yarns also protect the cable core against rodents and termites.

Total internal reflection:

Total internal reflection is a phenomenon that happens when a propagating wave strikes a medium boundary at an angle larger than a particular critical angle with respect to the normal to the surface. If the refractive index is lower on the other side of the boundary and the incident angle is greater than the critical angle, the wave cannot pass through and is entirely reflected. The **critical angle** is the angle of incidence above which the total internal reflectance occurs. This is particularly common as an optical phenomenon, where light waves are involved, but it occurs with many types of waves, such as electromagnetic waves in general or sound waves.

When a wave crosses a boundary between materials with different kinds of refractive indices, the wave will be partially refracted at the boundary surface, and partially reflected. However, if the angle of incidence is greater (i.e. the direction of propagation or ray is closer to being parallel to the boundary) than the critical angle – the angle of incidence at which light is refracted such that it travels along the boundary – then the wave will not cross the boundary and instead be totally reflected back internally. This can only occur where the wave travels from a medium with a higher refractive index (n_1) to one with a lower refractive index (n_2). For example, it will occur with light when passing from glass to air, but not when passing from air to glass.

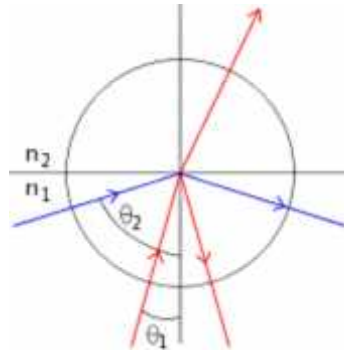

Under "ordinary conditions" it is true that the creation of an evanescent wave does not affect the conservation of energy, i.e. the evanescent wave transmits zero net energy. However, if a third medium with a higher refractive index than the low-index second medium is placed within less than several wavelengths distance from the interface between the first medium and the second medium, the evanescent wave will be different from the one under "ordinary conditions" and it will pass energy across the second into the third medium. (See evanescent wave coupling.) This process is called "frustrated" total internal reflection (FTIR) and is very similar to quantum tunneling. The quantum tunneling model is mathematically analogous if one thinks of the electromagnetic field as being the wave function of the photon. The low index medium can be thought of as a potential barrier through which photons can tunnel.

The transmission coefficient for FTIR is highly sensitive to the spacing between the high index media (the function is approximately exponential until the gap is almost closed), so this effect has often been used to modulate optical transmission and reflection with a large dynamic range. An example application of this principle is the multi-touch sensing technology for displays as developed at the New York University's Media Research Lab.

Acceptance angle:

A **guided ray** (also **bound ray** or **trapped ray**) is a ray of light in a multi-mode optical fiber, which is confined by the core. For step index fiber, light entering the fiber will be guided if it falls within the **acceptance cone** of the fiber, that is if it makes an angle with the fiber axis that is less than the **acceptance angle**,

$$\sin \theta \leq \sqrt{n_o^2 - n_c^2},$$

where

θ is the angle the ray makes with the fiber axis, *before* entering the fiber,

n_o is the refractive index along the central axis of the fiber, and

n_c is the refractive index of the cladding.

This result can be derived from Snell's law by considering the critical angle.

Rays that fall within this angular range are reflected from the core-cladding boundary by total internal reflection, and so are confined by the core. The confinement of light by the fiber can also be described in terms of bound modes or guided modes. This treatment is necessary when considering singlemode fiber, since the ray model does not accurately describe the propagation of light in this type of fiber.

numerical aperture:

In optics, the **numerical aperture (NA)** of an optical system is a dimensionless number that characterizes the range of angles over which the system can accept or emit light. By incorporating index of refraction in its definition, NA has the property that it is constant for a beam as it goes from one material to another provided there is no optical power at the interface. The exact definition of the term varies slightly between different areas of optics. Numerical aperture is commonly used in microscopy to describe the acceptance cone of an objective (and hence its light-gathering ability and resolution), and in fiber optics, in which it describes the range of angles within which light that is incident on the fiber will be transmitted along it.

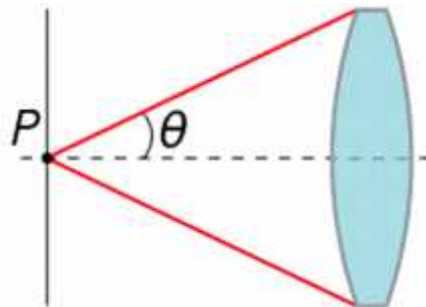

Numerical aperture versus f-number

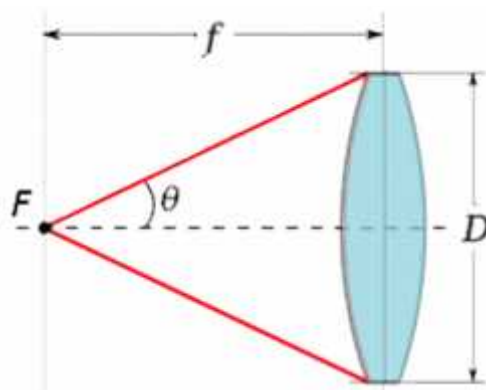

 Numerical aperture of a thin lens.

Numerical aperture is not typically used in photography. Instead, the angular aperture of a lens (or an imaging mirror) is expressed by the f-

number, written $f/\#$ or N , which is defined as the ratio of the focal length to the diameter of the entrance pupil:

$$N = f/D$$

This ratio is related to the image-space numerical aperture when the lens is focused at infinity.^[3] Based on the diagram at the right, the image-space numerical aperture of the lens is:

$$NA_i = n \sin \theta = n \sin \left[\arctan \left(\frac{D}{2f} \right) \right] \approx n \frac{D}{2f}$$

thus $N \approx \frac{1}{2 NA_i}$, assuming normal use in air ($n = 1$).

The approximation holds when the numerical aperture is small, but it turns out that for well-corrected optical systems such as camera lenses, a more detailed analysis shows that N is almost exactly equal to $1/(2NA_i)$ even at large numerical apertures. As Rudolf Kingslake explains, "It is a common error to suppose that the ratio $[D/2f]$ is actually equal to $\tan \theta$, and not $\sin \theta$... The tangent would, of course, be correct if the principal planes were really plane. However, the complete theory of the Abbe sine condition shows that if a lens is corrected for coma and spherical aberration, as all good photographic objectives must be, the second principal plane becomes a portion of a sphere of radius f centered about the focal point, ..." ^[4] In this sense, the traditional thin-lens definition and illustration of f-number is misleading, and defining it in terms of numerical aperture may be more meaningful.

Materials

Ducts can be made out of the following materials:

Galvanized mild steel is the standard and most common material used in fabricating ductwork. For insulation purposes, metal ducts are typically lined with faced fiber glass blanket (duct liner) or wrapped externally with fiber glass blankets (duct wrap).

Through the Light an optical fiber:

Through the Light" is a song performed by the British band Yes. It is the second-to-last song on their album *Drama* from 1980.

The song was originally called "Dancing Through the Light" and was demoed in 1979, while Jon Anderson and Rick Wakeman were still in the band. A demo version from that era is included on the 2004 reissue of *Drama*. With the arrival of Geoffrey Downes and Trevor Horn, the musical composition was finished and Horn wrote lyrics.

Chris Squire plays the electric piano on the song, and Trevor Horn plays fretless bass. Squire's electric piano is much more notable in the single version of the song, clearly audible in the beginning. The ending and other minimal details on the synthesizers and vocal tracks are different between the album and single versions.

A notable contribution to the sound of the song was apparently made by Hugh Padgham who was the recording engineer for the album, as the song features distinctive 'gated drum' sound which is often attributed to Padgham, made famous in recordings by The Police, Peter Gabriel, Phil Collins, and Genesis.

"Run Through the Light" is the only song from *Drama* that hasn't been performed live.

An **optical fiber** (or **optical fibre**) is a flexible, transparent fiber made of high quality extruded glass (silica) or plastic, slightly thicker than a human hair. It can function as a waveguide, or "light pipe", to transmit light between the two ends of the fiber. The field of applied science and engineering concerned with the design and application of optical fibers is known as **fiber optics**. Optical fibers are widely used in fiber-optic communications, which permits transmission over longer distances and at higher bandwidths (data rates) than other forms of communication. Fibers are used instead of metal wires because signals travel along them with less loss and are also immune to electromagnetic interference. Fibers are also used for illumination, and are wrapped in bundles so that they may be used to carry images, thus allowing viewing in confined spaces. Specially designed fibers are used for a variety of other applications, including sensors and fiber lasers.

Optical fibers typically include a transparent core surrounded by a transparent cladding material with a lower index of refraction. Light is kept in the core by total internal reflection. This causes the fiber to act as a waveguide. Fibers that support many propagation paths or transverse modes are called multi-mode fibers (MMF), while those that only support a single mode are called single-mode fibers (SMF). Multi-mode fibers generally have a wider core diameter, and are used for short-distance communication links and for applications where high power must be transmitted. Single-mode fibers are used for most communication links longer than 1,000 meters (3,300 ft).

Joining lengths of optical fiber is more complex than joining electrical wire or cable. The ends of the fibers must be carefully cleaved, and then spliced together, either mechanically or by fusing them with heat. Special optical fiber connectors for removable connections are also available.

Gradient-index fibre and index fibre:

Gradient-index (GRIN) optics is the branch of optics covering optical effects produced by a gradual variation of the refractive index of a material. Such variations can be used to produce lenses with flat surfaces, or lenses that do not have the aberrations typical of traditional spherical lenses. Gradient-index lenses may have a refraction gradient that is spherical, axial, or radial.

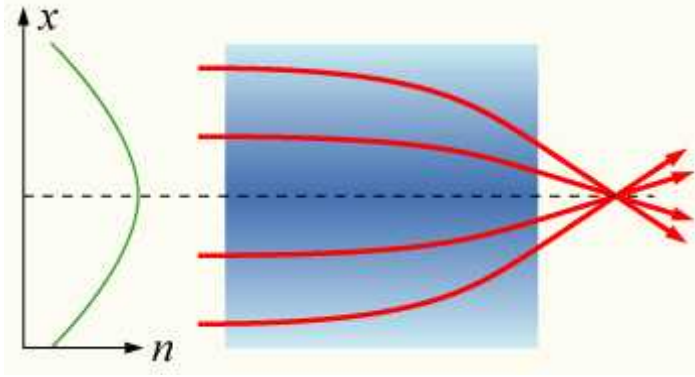

An **optical fiber** (or **optical fibre**) is a flexible, transparent fiber made of high quality extruded glass (silica) or plastic, slightly thicker than a human hair. It can function as a waveguide, or “light pipe”,^[1] to transmit light between the two ends of the fiber.^[2] The field of applied science and engineering concerned with the design and application of optical fibers is known as **fiber optics**. Optical fibers are widely used in fiber-optic communications, which permits transmission over longer distances and at higher bandwidths (data rates) than other forms of communication. Fibers are used instead of metal wires because signals travel along them with less loss and are also immune to electromagnetic interference. Fibers are also used for illumination, and are wrapped in bundles so that they may be used to carry images, thus allowing viewing in confined spaces. Specially designed fibers are used for a variety of other applications, including sensors and fiber lasers.

Optical fibers typically include a transparent core surrounded by a transparent cladding material with a lower index of refraction. Light is kept in the core by total internal reflection. This causes the fiber to act as a waveguide. Fibers that support many propagation paths or transverse modes are called multi-mode fibers (MMF), while those that only support a single mode are called single-mode fibers (SMF). Multi-mode fibers generally have a wider core diameter, and are used for short-distance communication links and for applications where high power must be transmitted. Single-mode fibers are used for most communication links longer than 1,000 meters (3,300 ft).

Joining lengths of optical fiber is more complex than joining electrical wire or cable. The ends of the fibers must be carefully cleaved, and then spliced

together, either mechanically or by fusing them with heat. Special optical fiber connectors for removable connections are also available.

Multi-mode optical fiber is a type of optical fiber mostly used for communication over short distances, such as within a building or on a campus. Typical multimode links have data rates of 10 Mbit/s to 10 Gbit/s over link lengths of up to 600 meters (2000 feet) and 10 Gbit/s for 300m (1000 feet) — more than sufficient for the majority of premises applications.

Multi-mode fibers are described by their core and cladding diameters. Thus, 62.5/125 μm multi-mode fiber has a core size of 62.5 micrometres (μm) and a cladding diameter of 125 μm . The transition between the core and cladding can be sharp, which is called a step-index profile, or a gradual transition, which is called a graded-index profile. The two types have different dispersion characteristics and thus different effective propagation distance. Multi-mode fibers may be constructed with either graded or step-index profile

In addition, multi-mode fibers are described using a system of classification determined by the ISO 11801 standard — OM1, OM2, and OM3 — which is based on the modal bandwidth of the multi-mode fiber. OM4 (defined in TIA-492-AAAD) was finalized in August 2009,^[7] and was published by the end of 2009 by the TIA. OM4 cable will support 125m links at 40 and 100 Gbit/s. The letters "OM" stand for *optical multi-mode*.

For many years 62.5/125 μm (OM1) and conventional 50/125 μm multi-mode fiber (OM2) were widely deployed in premises applications. These fibers easily support applications ranging from Ethernet (10 Mbit/s) to Gigabit Ethernet (1 Gbit/s) and, because of their relatively large core size, were ideal for use with LED transmitters. Newer deployments often use laser-optimized 50/125 μm multi-mode fiber (OM3). Fibers that meet this designation provide sufficient bandwidth to support 10 Gigabit Ethernet up to 300 meters. Optical fiber manufacturers have greatly refined their manufacturing process since that standard was issued and cables can be made that support 10 GbE up to 550 meters. Laser optimized multi-mode fiber (LOMMF) is designed for use with 850 nm VCSELs.

The migration to LOMMF/OM3 has occurred as users upgrade to higher speed networks. LEDs have a maximum modulation rate of 622 Mbit/s because they can not be turned on/off fast enough to support higher bandwidth applications. VCSELs are capable of modulation over 10 Gbit/s and are used in many high speed networks.

Cables can sometimes be distinguished by jacket color: for 62.5/125 μm (OM1) and 50/125 μm (OM2), orange jackets are recommended, while Aqua is recommended for 50/125 μm "laser optimized" OM3 and OM4 fiber.^[4]

VCSEL power profiles, along with variations in fiber uniformity, can cause modal dispersion which is measured by differential modal delay (DMD). Modal dispersion is caused by the different speeds of the individual modes in a light pulse. The net effect causes the light pulse to spread over distance, introducing intersymbol interference. The greater the length, the greater the modal dispersion. To combat modal dispersion, LOMMF is manufactured in a way that eliminates variations in the fiber which could affect the speed that a light pulse can travel. The refractive index profile is enhanced for VCSEL transmission and to prevent pulse spreading. As a result the fibers maintain signal integrity over longer distances, thereby maximizing the bandwidth.

In fiber optics, a **graded-index** or **gradient-index fiber** is an optical fiber whose core has a refractive index that decreases with increasing radial distance from the optical axis of the fiber.

Because parts of the core closer to the fiber axis have a higher refractive index than the parts near the cladding, light rays follow sinusoidal paths down the fiber. The most common refractive index profile for a graded-index fiber is very nearly parabolic. The parabolic profile results in continual refocusing of the rays in the core, and minimizes modal dispersion.

Multi-mode optical fiber can be built with either graded index or step index. The advantage of the graded index compared to step index is the considerable decrease in modal dispersion.

This type of fiber is normalized by the International Telecommunications Union ITU-T at recommendation

Fibre optic communications link:

In telecommunication a **data link** is the means of connecting one location to another for the purpose of transmitting and receiving digital information. It can also refer to a set of electronics assemblies, consisting of a transmitter and a receiver (two pieces of data terminal equipment) and the interconnecting data telecommunication circuit. These are governed by a link protocol enabling digital data to be transferred from a data source to a data sink.

There are at least three types of basic data-link configurations that can be conceived of and used:

- Simplex communications, most commonly meaning all communications in one direction only.
- Half-duplex communications, meaning communications in both directions, but not both ways simultaneously.
- Duplex communications, communications in both directions simultaneously.

In civil aviation, a data-link system (known as Controller Pilot Data Link Communications) is used to send information between aircraft and air traffic controllers when an aircraft is too far from the ATC to make voice radio communication and radar observations possible. Such systems are used for aircraft crossing the Atlantic and Pacific oceans. One such system, used by NavCanada and NATS over the North Atlantic, uses a five-digit data link sequence number confirmed between air traffic control and the pilots of the aircraft before the aircraft proceeds to cross the ocean. This system uses the aircraft's flight management computer to send location, speed and altitude information about the aircraft to the ATC. ATC can then send messages to the aircraft regarding any necessary change of course.

In military aviation, a data-link may also carry weapons targeting information or information to help warplanes land on aircraft carriers.

In unmanned aircraft, land vehicles, boats, and spacecraft, a two-way (full-duplex or half-duplex) data-link is used to send control signals, and to receive telemetry.

